

APPENDIX III:

UNIVERSITY OF ARIZONA RATE STUDY

General Information

GENERAL INFORMATION				
Calculated rates will be charged during the following year:	FY2017			
Calculated Rates are based on the following year:	FY2016			
Depreciation Recapture Method	Billing Rates			
DEPARTMENT INFORMATION				
Department Name/Number	Arizona State Museum / 0201			
Name of Service Center	Arizona State Museum State Mandated Programs			
Purpose of Service Center				
Service Center Account Number	2488800			
Operations Subsidy Account Number 1				
Operations Subsidy Account Number 2				
Operations Subsidy Account Number 3				
Operations Subsidy Account Number 4				
Operations Subsidy Account Number 5				
CONTACT INFORMATION		Name	Email	Phone number
Account Manager	Lyons,Patrick D	plyons@email.arizona.edu	(520) 621-6281	
Director, Arizona State Museum	Lyons,Patrick D	plyons@email.arizona.edu	(520) 621-6281	
Associate Curator/Head of Collections	Eckert,Suzanne Lorraine	sleckert@email.arizona.edu	(520) 621-6281	
Department Head	Espy,Kimberly Andrews	kespy@email.arizona.edu	(520) 621-3513	

Box Storage Costs

Item	Annual Cost
Total Fixed Costs	-

Annual Discount Rate	Annual Inflation Rate	Net Monthly Rate
7.20%	1.70%	0.46%

Item	Cost	Quantity per Box	One Time Costs
Shelving per 1' box	56.95	1.00	56.95
Standard white archival box	10.45	1.00	10.45
Median size bag	0.10	20.00	2.00
Acid free card stock	0.03	20.00	0.55
Space/Rent	6.82	12.00	81.88
Archival Pen	2.89	0.50	1.45
Total Year One Expenses			153.28

Item	Cost	Quantity per Year	Annual Cost	Cost Per Month	Perpetuity Cost
Shelving per 1' box	56.95	0.05	2.85	0.24	51.82
Standard white archival box	10.45	0.20	2.09	0.17	38.00
Inventory Labor	49.96	1.00	49.96	4.16	908.36
Space/Rent	6.82	12.00	81.88	6.82	1,488.73
Total Recurring Expenses	124.19		136.78	11.40	2,486.91

At MAXIMUM efficiency, shelving units provide 6,026 archive boxes storage in a footprint of 1,305.85 square feet (53.3' x 24.5'). In order to maintain efficiency and provide realistic shelving and space costs per box, we estimate 80% efficiency on storage.

Shelving Charge			
Boxes per Carriage	Carriage Cost	Efficiency	Cost per Box
336	15,309.28	80.00%	56.95

Space/Rent Charge			
Boxes per Area	Area (Sqft)	Efficiency	Sqft per Box
6,026	1,305.85	80.00%	0.27

Box Storage Costs

Amortization of Perpetuity Costs		
	Revenue Recognized	Liability Balance
Time of Sale	\$0.00	\$2,486.91
Year 1	\$132.79	\$2,354.12
Year 2	\$125.70	\$2,228.42
Year 3	\$118.99	\$2,109.43
Year 4	\$112.63	\$1,996.80
Year 5	\$106.62	\$1,890.17
Year 6	\$100.93	\$1,789.25
Year 7	\$95.54	\$1,693.71
Year 8	\$90.44	\$1,603.27
Year 9	\$85.61	\$1,517.66
Year 10	\$81.04	\$1,436.63
Year 11	\$76.71	\$1,359.92
Year 12	\$72.61	\$1,287.30
Year 13	\$68.74	\$1,218.57
Year 14	\$65.07	\$1,153.50
Year 15	\$61.59	\$1,091.91
Year 16	\$58.30	\$1,033.60
Year 17	\$55.19	\$978.41
Year 18	\$52.24	\$926.17
Year 19	\$49.45	\$876.72
Year 20	\$46.81	\$829.90
Year 21	\$44.31	\$785.59
Year 22	\$41.95	\$743.64
Year 23	\$39.71	\$703.94
Year 24	\$37.59	\$666.35
Year 25	\$35.58	\$630.77
Year 26	\$33.68	\$597.09
Year 27	\$31.88	\$565.21
Year 28	\$30.18	\$535.03
Year 29	\$28.57	\$506.46
Year 30	\$27.04	\$479.41
Year 31	\$25.60	\$453.82
Year 32	\$24.23	\$429.58
Year 33	\$22.94	\$406.65
Year 34	\$21.71	\$384.93
Year 35	\$20.55	\$364.38
Year 36	\$19.46	\$344.92
Year 37	\$18.42	\$326.51
Year 38	\$17.43	\$309.07
Year 39	\$16.50	\$292.57
Year 40	\$15.62	\$276.95
Year 41	\$14.79	\$262.16
Year 42	\$14.00	\$248.16
Year 43	\$13.25	\$234.91

Box Storage Costs

Year 44	\$12.54	\$222.37
Year 45	\$11.87	\$210.49
Year 46	\$11.24	\$199.25
Year 47	\$10.64	\$188.61
Year 48	\$10.07	\$178.54
Year 49	\$9.53	\$169.01
Year 50	\$9.02	\$159.98
Year 51	\$8.54	\$151.44
Year 52	\$8.09	\$143.36
Year 53	\$7.65	\$135.70
Year 54	\$7.25	\$128.46
Year 55	\$6.86	\$121.60
Year 56	\$6.49	\$115.10
Year 57	\$6.15	\$108.96
Year 58	\$5.82	\$103.14
Year 59	\$5.51	\$97.63
Year 60	\$5.21	\$92.42
Year 61	\$4.93	\$87.48
Year 62	\$4.67	\$82.81
Year 63	\$4.42	\$78.39
Year 64	\$4.19	\$74.21
Year 65	\$3.96	\$70.24
Year 66	\$3.75	\$66.49
Year 67	\$3.55	\$62.94
Year 68	\$3.36	\$59.58
Year 69	\$3.18	\$56.40
Year 70	\$3.01	\$53.39
Year 71	\$2.85	\$50.54
Year 72	\$2.70	\$47.84
Year 73	\$2.55	\$45.28
Year 74	\$2.42	\$42.87
Year 75	\$2.29	\$40.58
Year 76	\$2.17	\$38.41
Year 77	\$2.05	\$36.36
Year 78	\$1.94	\$34.42
Year 79	\$1.84	\$32.58
Year 80	\$1.74	\$30.84
Year 81	\$1.65	\$29.19
Year 82	\$1.56	\$27.64
Year 83	\$1.48	\$26.16
Year 84	\$1.40	\$24.76
Year 85	\$1.32	\$23.44
Year 86	\$1.25	\$22.19
Year 87	\$1.18	\$21.00
Year 88	\$1.12	\$19.88
Year 89	\$1.06	\$18.82
Year 90	\$1.00	\$17.82

Box Storage Costs

Year 91	\$0.95	\$16.86
Year 92	\$0.90	\$15.96
Year 93	\$0.85	\$15.11
Year 94	\$0.81	\$14.30
Year 95	\$0.76	\$13.54
Year 96	\$0.72	\$12.82
Year 97	\$0.68	\$12.13
Year 98	\$0.65	\$11.49
Year 99	\$0.61	\$10.87
Year 100	\$0.58	\$10.29
Year 101	\$0.55	\$9.74
Year 102	\$0.52	\$9.22
Year 103	\$0.49	\$8.73
Year 104	\$0.47	\$8.26
Year 105	\$0.44	\$7.82
Year 106	\$0.42	\$7.40
Year 107	\$0.40	\$7.01
Year 108	\$0.37	\$6.64
Year 109	\$0.35	\$6.28
Year 110	\$0.34	\$5.95
Year 111	\$0.32	\$5.63
Year 112	\$0.30	\$5.33
Year 113	\$0.28	\$5.04
Year 114	\$0.27	\$4.77
Year 115	\$0.25	\$4.52
Year 116	\$0.24	\$4.28
Year 117	\$0.23	\$4.05
Year 118	\$0.22	\$3.83
Year 119	\$0.20	\$3.63
Year 120	\$0.19	\$3.43
Year 121	\$0.18	\$3.25
Year 122	\$0.17	\$3.08
Year 123	\$0.16	\$2.91
Year 124	\$0.16	\$2.76
Year 125	\$0.15	\$2.61
Year 126	\$0.14	\$2.47
Year 127	\$0.13	\$2.34
Year 128	\$0.12	\$2.21
Year 129	\$0.12	\$2.10
Year 130	\$0.11	\$1.98
Year 131	\$0.11	\$1.88
Year 132	\$0.10	\$1.78
Year 133	\$0.09	\$1.68
Year 134	\$0.09	\$1.59
Year 135	\$0.09	\$1.51
Year 136	\$0.08	\$1.43
Year 137	\$0.08	\$1.35

Box Storage Costs

Year 138	\$0.07	\$1.28
Year 139	\$0.07	\$1.21
Year 140	\$0.06	\$1.15
Year 141	\$0.06	\$1.08
Year 142	\$0.06	\$1.03
Year 143	\$0.05	\$0.97
Year 144	\$0.05	\$0.92
Year 145	\$0.05	\$0.87
Year 146	\$0.05	\$0.82
Year 147	\$0.04	\$0.78
Year 148	\$0.04	\$0.74
Year 149	\$0.04	\$0.70
Year 150	\$0.04	\$0.66
Year 151	\$0.04	\$0.63
Year 152	\$0.03	\$0.59
Year 153	\$0.03	\$0.56
Year 154	\$0.03	\$0.53
Year 155	\$0.03	\$0.50
Year 156	\$0.03	\$0.48
Year 157	\$0.03	\$0.45
Year 158	\$0.02	\$0.43
Year 159	\$0.02	\$0.40
Year 160	\$0.02	\$0.38
Year 161	\$0.02	\$0.36
Year 162	\$0.02	\$0.34
Year 163	\$0.02	\$0.32
Year 164	\$0.02	\$0.31
Year 165	\$0.02	\$0.29
Year 166	\$0.02	\$0.28
Year 167	\$0.01	\$0.26
Year 168	\$0.01	\$0.25
Year 169	\$0.01	\$0.23
Year 170	\$0.01	\$0.22
Year 171	\$0.01	\$0.21
Year 172	\$0.01	\$0.20
Year 173	\$0.01	\$0.19
Year 174	\$0.01	\$0.18
Year 175	\$0.01	\$0.17
Year 176	\$0.01	\$0.16
Year 177	\$0.01	\$0.15
Year 178	\$0.01	\$0.14
Year 179	\$0.01	\$0.13
Year 180	\$0.13	\$0.00

Billable Filing Costs

Item	Annual Cost
Total Fixed Costs	-

Annual Discount Rate	Annual Inflation Rate	Net Monthly Rate
7.20%	1.70%	0.46%

Item	Cost	Quantity per Linear Ft	One Time Costs
Linear Foot of Shelving	56.95	1.00	56.95
Folders	0.26	14.40	3.74
Space/Rent	6.82	12.00	81.88
2.5" Document Box	5.04	4.80	24.19
			166.76

Item	Cost	Quantity per Year	Annual Cost	Cost Per Month	Perpetuity Cost
Linear Foot of Shelving	56.95	0.05	2.85	0.24	51.82
Folders	0.26	2.88	0.75	0.06	13.64
Inventory Labor	24.98	1.00	24.98	2.08	454.18
Space/Rent	6.82	12.00	81.88	6.82	1,488.73
2.5" Document Box	5.04	0.96	4.84	0.40	88.00
			115.30	9.61	2,096.37

At **MAXIMUM** efficiency, shelving units provide 6,026 archive boxes storage in a footprint of 1,305.85 square feet (53.3' x 24.5'). In order to maintain efficiency and provide realistic shelving and space costs per box, we estimate 80% efficiency on storage.

Shelving Charge			
Linear feet per Carriage	Carriage Cost	Efficiency	Cost per Linear ft
336	15,309.28	80.00%	56.95

Space/Rent Charge			
Linear Feet per Area	Area (Sqft)	Efficiency	Sqft per Linear ft
6,026	1,305.85	80.00%	0.27

Billable Filing Costs

Amortization of Perpetuity Costs		
	Revenue Recognized	Liability Balance
Time of Sale	\$0.00	\$2,096.37
Year 1	\$111.94	\$1,984.43
Year 2	\$105.96	\$1,878.47
Year 3	\$100.30	\$1,778.17
Year 4	\$94.95	\$1,683.22
Year 5	\$89.88	\$1,593.34
Year 6	\$85.08	\$1,508.27
Year 7	\$80.54	\$1,427.73
Year 8	\$76.24	\$1,351.50
Year 9	\$72.16	\$1,279.33
Year 10	\$68.31	\$1,211.02
Year 11	\$64.66	\$1,146.36
Year 12	\$61.21	\$1,085.15
Year 13	\$57.94	\$1,027.20
Year 14	\$54.85	\$972.36
Year 15	\$51.92	\$920.44
Year 16	\$49.15	\$871.29
Year 17	\$46.52	\$824.77
Year 18	\$44.04	\$780.73
Year 19	\$41.69	\$739.04
Year 20	\$39.46	\$699.58
Year 21	\$37.35	\$662.22
Year 22	\$35.36	\$626.86
Year 23	\$33.47	\$593.39
Year 24	\$31.68	\$561.71
Year 25	\$29.99	\$531.71
Year 26	\$28.39	\$503.32
Year 27	\$26.88	\$476.45
Year 28	\$25.44	\$451.01
Year 29	\$24.08	\$426.92
Year 30	\$22.80	\$404.13
Year 31	\$21.58	\$382.55
Year 32	\$20.43	\$362.12
Year 33	\$19.34	\$342.79
Year 34	\$18.30	\$324.48
Year 35	\$17.33	\$307.16
Year 36	\$16.40	\$290.76
Year 37	\$15.53	\$275.23
Year 38	\$14.70	\$260.54
Year 39	\$13.91	\$246.62
Year 40	\$13.17	\$233.45
Year 41	\$12.47	\$220.99
Year 42	\$11.80	\$209.19
Year 43	\$11.17	\$198.02

Billable Filing Costs

Year 44	\$10.57	\$187.45
Year 45	\$10.01	\$177.44
Year 46	\$9.47	\$167.96
Year 47	\$8.97	\$158.99
Year 48	\$8.49	\$150.50
Year 49	\$8.04	\$142.47
Year 50	\$7.61	\$134.86
Year 51	\$7.20	\$127.66
Year 52	\$6.82	\$120.84
Year 53	\$6.45	\$114.39
Year 54	\$6.11	\$108.28
Year 55	\$5.78	\$102.50
Year 56	\$5.47	\$97.03
Year 57	\$5.18	\$91.85
Year 58	\$4.90	\$86.94
Year 59	\$4.64	\$82.30
Year 60	\$4.39	\$77.91
Year 61	\$4.16	\$73.75
Year 62	\$3.94	\$69.81
Year 63	\$3.73	\$66.08
Year 64	\$3.53	\$62.55
Year 65	\$3.34	\$59.21
Year 66	\$3.16	\$56.05
Year 67	\$2.99	\$53.06
Year 68	\$2.83	\$50.22
Year 69	\$2.68	\$47.54
Year 70	\$2.54	\$45.00
Year 71	\$2.40	\$42.60
Year 72	\$2.27	\$40.33
Year 73	\$2.15	\$38.17
Year 74	\$2.04	\$36.13
Year 75	\$1.93	\$34.21
Year 76	\$1.83	\$32.38
Year 77	\$1.73	\$30.65
Year 78	\$1.64	\$29.01
Year 79	\$1.55	\$27.46
Year 80	\$1.47	\$26.00
Year 81	\$1.39	\$24.61
Year 82	\$1.31	\$23.30
Year 83	\$1.24	\$22.05
Year 84	\$1.18	\$20.87
Year 85	\$1.11	\$19.76
Year 86	\$1.06	\$18.70
Year 87	\$1.00	\$17.71
Year 88	\$0.95	\$16.76
Year 89	\$0.89	\$15.87
Year 90	\$0.85	\$15.02

Billable Filing Costs

Year 91	\$0.80	\$14.22
Year 92	\$0.76	\$13.46
Year 93	\$0.72	\$12.74
Year 94	\$0.68	\$12.06
Year 95	\$0.64	\$11.41
Year 96	\$0.61	\$10.81
Year 97	\$0.58	\$10.23
Year 98	\$0.55	\$9.68
Year 99	\$0.52	\$9.17
Year 100	\$0.49	\$8.68
Year 101	\$0.46	\$8.21
Year 102	\$0.44	\$7.77
Year 103	\$0.42	\$7.36
Year 104	\$0.39	\$6.97
Year 105	\$0.37	\$6.59
Year 106	\$0.35	\$6.24
Year 107	\$0.33	\$5.91
Year 108	\$0.32	\$5.59
Year 109	\$0.30	\$5.29
Year 110	\$0.28	\$5.01
Year 111	\$0.27	\$4.74
Year 112	\$0.25	\$4.49
Year 113	\$0.24	\$4.25
Year 114	\$0.23	\$4.02
Year 115	\$0.21	\$3.81
Year 116	\$0.20	\$3.61
Year 117	\$0.19	\$3.41
Year 118	\$0.18	\$3.23
Year 119	\$0.17	\$3.06
Year 120	\$0.16	\$2.90
Year 121	\$0.15	\$2.74
Year 122	\$0.15	\$2.59
Year 123	\$0.14	\$2.46
Year 124	\$0.13	\$2.32
Year 125	\$0.12	\$2.20
Year 126	\$0.12	\$2.08
Year 127	\$0.11	\$1.97
Year 128	\$0.11	\$1.87
Year 129	\$0.10	\$1.77
Year 130	\$0.09	\$1.67
Year 131	\$0.09	\$1.58
Year 132	\$0.08	\$1.50
Year 133	\$0.08	\$1.42
Year 134	\$0.08	\$1.34
Year 135	\$0.07	\$1.27
Year 136	\$0.07	\$1.20
Year 137	\$0.06	\$1.14

Billable Filing Costs

Year 138	\$0.06	\$1.08
Year 139	\$0.06	\$1.02
Year 140	\$0.05	\$0.97
Year 141	\$0.05	\$0.91
Year 142	\$0.05	\$0.87
Year 143	\$0.05	\$0.82
Year 144	\$0.04	\$0.78
Year 145	\$0.04	\$0.73
Year 146	\$0.04	\$0.70
Year 147	\$0.04	\$0.66
Year 148	\$0.04	\$0.62
Year 149	\$0.03	\$0.59
Year 150	\$0.03	\$0.56
Year 151	\$0.03	\$0.53
Year 152	\$0.03	\$0.50
Year 153	\$0.03	\$0.47
Year 154	\$0.03	\$0.45
Year 155	\$0.02	\$0.42
Year 156	\$0.02	\$0.40
Year 157	\$0.02	\$0.38
Year 158	\$0.02	\$0.36
Year 159	\$0.02	\$0.34
Year 160	\$0.02	\$0.32
Year 161	\$0.02	\$0.31
Year 162	\$0.02	\$0.29
Year 163	\$0.02	\$0.27
Year 164	\$0.01	\$0.26
Year 165	\$0.01	\$0.25
Year 166	\$0.01	\$0.23
Year 167	\$0.01	\$0.22
Year 168	\$0.01	\$0.21
Year 169	\$0.01	\$0.20
Year 170	\$0.01	\$0.19
Year 171	\$0.01	\$0.18
Year 172	\$0.01	\$0.17
Year 173	\$0.01	\$0.16
Year 174	\$0.01	\$0.15
Year 175	\$0.01	\$0.14
Year 176	\$0.01	\$0.13
Year 177	\$0.01	\$0.13
Year 178	\$0.01	\$0.12
Year 179	\$0.01	\$0.11
Year 180	\$0.11	\$0.00

Permit Issuance Costs

Item	Annual Cost
Total Fixed Costs	-

Annual Discount Rate	Annual Inflation Rate	Net Monthly Rate
7.20%	1.70%	0.46%

Item	Cost	Quantity per Permit	One Time Costs
Avg 2" of Linear Shelving	9.49	1.00	9.49
Folders	0.26	2.00	0.52
Document Box	5.04	1.00	5.04
			15.05

Item	Cost	Quantity per Year	Annual Cost	Cost Per Month	Perpetuity Cost
Avg 2" of Linear Shelving	9.49	0.05	0.47	0.04	8.55
Folders	0.26	0.80	0.21	0.02	3.82
Inventory Labor	24.98	1.00	24.98	2.08	454.18
Space/Rent Avg 2"	1.14	12.00	13.65	1.14	248.18
Document Box	5.04	0.20	1.01	0.08	18.36
			40.32	3.36	733.09

At **MAXIMUM** efficiency, shelving units provide 6,026 archive boxes storage in a footprint of 1,305.85 square feet (53.3' x 24.5'). In order to maintain efficiency and provide realistic shelving and space costs per box, we estimate 80% efficiency on storage.

Shelving Charge			
Linear feet per Carriage	Carriage Cost	Efficiency	Cost per Linear ft
336	15,309.28	80.00%	56.95

Space/Rent Charge			
Linear Feet per Area	Area (Sqft)	Efficiency	Sqft per Linear ft
6,026	1,305.85	80.00%	0.27

Permit Issuance Costs

Amortization of Perpetuity Costs		
	Revenue Recognized	Liability Balance
Time of Sale	\$0.00	\$733.09
Year 1	\$39.14	\$693.95
Year 2	\$37.05	\$656.89
Year 3	\$35.08	\$621.82
Year 4	\$33.20	\$588.61
Year 5	\$31.43	\$557.18
Year 6	\$29.75	\$527.43
Year 7	\$28.16	\$499.27
Year 8	\$26.66	\$472.61
Year 9	\$25.24	\$447.38
Year 10	\$23.89	\$423.49
Year 11	\$22.61	\$400.88
Year 12	\$21.41	\$379.47
Year 13	\$20.26	\$359.21
Year 14	\$19.18	\$340.03
Year 15	\$18.16	\$321.87
Year 16	\$17.19	\$304.69
Year 17	\$16.27	\$288.42
Year 18	\$15.40	\$273.02
Year 19	\$14.58	\$258.44
Year 20	\$13.80	\$244.64
Year 21	\$13.06	\$231.58
Year 22	\$12.37	\$219.21
Year 23	\$11.70	\$207.51
Year 24	\$11.08	\$196.43
Year 25	\$10.49	\$185.94
Year 26	\$9.93	\$176.01
Year 27	\$9.40	\$166.61
Year 28	\$8.90	\$157.71
Year 29	\$8.42	\$149.29
Year 30	\$7.97	\$141.32
Year 31	\$7.55	\$133.78
Year 32	\$7.14	\$126.63
Year 33	\$6.76	\$119.87
Year 34	\$6.40	\$113.47
Year 35	\$6.06	\$107.41
Year 36	\$5.74	\$101.68
Year 37	\$5.43	\$96.25
Year 38	\$5.14	\$91.11
Year 39	\$4.86	\$86.24
Year 40	\$4.61	\$81.64
Year 41	\$4.36	\$77.28
Year 42	\$4.13	\$73.15
Year 43	\$3.91	\$69.25

Permit Issuance Costs

Year 44	\$3.70	\$65.55
Year 45	\$3.50	\$62.05
Year 46	\$3.31	\$58.74
Year 47	\$3.14	\$55.60
Year 48	\$2.97	\$52.63
Year 49	\$2.81	\$49.82
Year 50	\$2.66	\$47.16
Year 51	\$2.52	\$44.64
Year 52	\$2.38	\$42.26
Year 53	\$2.26	\$40.00
Year 54	\$2.14	\$37.87
Year 55	\$2.02	\$35.84
Year 56	\$1.91	\$33.93
Year 57	\$1.81	\$32.12
Year 58	\$1.71	\$30.40
Year 59	\$1.62	\$28.78
Year 60	\$1.54	\$27.24
Year 61	\$1.45	\$25.79
Year 62	\$1.38	\$24.41
Year 63	\$1.30	\$23.11
Year 64	\$1.23	\$21.87
Year 65	\$1.17	\$20.71
Year 66	\$1.11	\$19.60
Year 67	\$1.05	\$18.55
Year 68	\$0.99	\$17.56
Year 69	\$0.94	\$16.63
Year 70	\$0.89	\$15.74
Year 71	\$0.84	\$14.90
Year 72	\$0.80	\$14.10
Year 73	\$0.75	\$13.35
Year 74	\$0.71	\$12.64
Year 75	\$0.67	\$11.96
Year 76	\$0.64	\$11.32
Year 77	\$0.60	\$10.72
Year 78	\$0.57	\$10.15
Year 79	\$0.54	\$9.60
Year 80	\$0.51	\$9.09
Year 81	\$0.49	\$8.61
Year 82	\$0.46	\$8.15
Year 83	\$0.43	\$7.71
Year 84	\$0.41	\$7.30
Year 85	\$0.39	\$6.91
Year 86	\$0.37	\$6.54
Year 87	\$0.35	\$6.19
Year 88	\$0.33	\$5.86
Year 89	\$0.31	\$5.55
Year 90	\$0.30	\$5.25

Permit Issuance Costs

Year 91	\$0.28	\$4.97
Year 92	\$0.27	\$4.71
Year 93	\$0.25	\$4.45
Year 94	\$0.24	\$4.22
Year 95	\$0.23	\$3.99
Year 96	\$0.21	\$3.78
Year 97	\$0.20	\$3.58
Year 98	\$0.19	\$3.39
Year 99	\$0.18	\$3.20
Year 100	\$0.17	\$3.03
Year 101	\$0.16	\$2.87
Year 102	\$0.15	\$2.72
Year 103	\$0.15	\$2.57
Year 104	\$0.14	\$2.44
Year 105	\$0.13	\$2.31
Year 106	\$0.12	\$2.18
Year 107	\$0.12	\$2.07
Year 108	\$0.11	\$1.96
Year 109	\$0.10	\$1.85
Year 110	\$0.10	\$1.75
Year 111	\$0.09	\$1.66
Year 112	\$0.09	\$1.57
Year 113	\$0.08	\$1.49
Year 114	\$0.08	\$1.41
Year 115	\$0.08	\$1.33
Year 116	\$0.07	\$1.26
Year 117	\$0.07	\$1.19
Year 118	\$0.06	\$1.13
Year 119	\$0.06	\$1.07
Year 120	\$0.06	\$1.01
Year 121	\$0.05	\$0.96
Year 122	\$0.05	\$0.91
Year 123	\$0.05	\$0.86
Year 124	\$0.05	\$0.81
Year 125	\$0.04	\$0.77
Year 126	\$0.04	\$0.73
Year 127	\$0.04	\$0.69
Year 128	\$0.04	\$0.65
Year 129	\$0.03	\$0.62
Year 130	\$0.03	\$0.58
Year 131	\$0.03	\$0.55
Year 132	\$0.03	\$0.52
Year 133	\$0.03	\$0.50
Year 134	\$0.03	\$0.47
Year 135	\$0.03	\$0.44
Year 136	\$0.02	\$0.42
Year 137	\$0.02	\$0.40

Permit Issuance Costs

Year 138	\$0.02	\$0.38
Year 139	\$0.02	\$0.36
Year 140	\$0.02	\$0.34
Year 141	\$0.02	\$0.32
Year 142	\$0.02	\$0.30
Year 143	\$0.02	\$0.29
Year 144	\$0.02	\$0.27
Year 145	\$0.01	\$0.26
Year 146	\$0.01	\$0.24
Year 147	\$0.01	\$0.23
Year 148	\$0.01	\$0.22
Year 149	\$0.01	\$0.21
Year 150	\$0.01	\$0.20
Year 151	\$0.01	\$0.18
Year 152	\$0.01	\$0.17
Year 153	\$0.01	\$0.17
Year 154	\$0.01	\$0.16
Year 155	\$0.01	\$0.15
Year 156	\$0.01	\$0.14
Year 157	\$0.01	\$0.13
Year 158	\$0.01	\$0.13
Year 159	\$0.01	\$0.12
Year 160	\$0.01	\$0.11
Year 161	\$0.01	\$0.11
Year 162	\$0.01	\$0.10
Year 163	\$0.01	\$0.10
Year 164	\$0.01	\$0.09
Year 165	\$0.00	\$0.09
Year 166	\$0.00	\$0.08
Year 167	\$0.00	\$0.08
Year 168	\$0.00	\$0.07
Year 169	\$0.00	\$0.07
Year 170	\$0.00	\$0.07
Year 171	\$0.00	\$0.06
Year 172	\$0.00	\$0.06
Year 173	\$0.00	\$0.06
Year 174	\$0.00	\$0.05
Year 175	\$0.00	\$0.05
Year 176	\$0.00	\$0.05
Year 177	\$0.00	\$0.04
Year 178	\$0.00	\$0.04
Year 179	\$0.00	\$0.04
Year 180	\$0.04	\$0.00

AZSite Annual Costs

Item	Annual Cost
ASU Annual Bill	17,000.00
Travel to Quarterly Meetings	11,000.00
San Miguel Students (1/3 of 4 @.25 FTE)	7,666.67
Depreciation (see below)	5,612.72
Total Fixed Costs	41,279.39

Item	Cost Per Subscription
Total Cost Per Subscription	-

Item	Unit Cost	Qty	Life	Annual Depreciation
Scanner (Large bed for maps, etc.)	2,000.00	1.00	5	400.00
Computer	2,000.00	13.03	5	5,212.72
Total Annual Equipment Depreciation or Recovery for Non-Capital Items				5,612.72

Equipment and Office Supplies

Item	Annual Cost
Paper	2,000.00
Ink/Toner	200.00
General Office Supplies	807.97
4-Ply Plastic Bags	2,000.00
Total Fixed Costs	5,007.97

Item	Unit Cost	Qty	Life	Annual Depreciation
Computers	2,000.00	13.03	5	5,212.72
Photocopiers	7,500.00	2.00	7	2,142.86
Scanner (Large bed for maps, etc.)	2,000.00	1.00	5	400.00
Total Annual Equipment Depreciation or Recovery for Non-Capital Items				7,755.58

Number of computers equivalent to total FTEs assigned to mandated programs. /nbc

Environmental Costs

Item	Annual Cost
eClimateNotebook	959.40
Lift Battery/Repair	150.00
Total Fixed Costs	1,109.40

Item	Cost	Quantity	One Time Costs
			-
			-
			-
			-
			-
			-
Total Year One Variable Expenses			-

Item	Unit Cost	Qty	Life	Annual Depreciation
PEM2 Dataloggers	315.74	39.00	5	2,462.80
Personnel Lift	5,000.00	1.00	15	333.33
Total Annual Depreciation Expense or Recovery for Non-Capital Iter				2,796.13
Total Annual Environmental Costs				3,905.53

Substantiation for PEM2 Dataloggers. 22 already on hand, and an additional 56 needed per external auditor. 50% of these allocated to mandated services based on proportion of collection. /nbc

List of Rates and Cost Pools

Rate ID	Rate Type	Name of Service	Sub Account	Unit Base	Est. Productive Billable Units	Est Avg Var Cost Per Unit	Est. Total Fixed Cost	Total Est. Variable Costs	Total Direct Operational Costs
Assistants	Unit Price	Per hour charge for basic services provided.	ASSTS	Hr	1,255.00			1,255.00	1,255.00
Specialist	Unit Price	Per hour charge for specialist services provided.	SPECL	Hr	6,055.00			6,055.00	6,055.00
Professional	Unit Price	Per hour charge for professional services provided.	PROFS	Hr	1,545.00			1,545.00	1,545.00
AZSite	Unit Price	Annual Subscription to AZSite Database	AZSte	Ea	264.00	-	41,279.39	-	41,279.39
NAGPRA	Unit Price	Federally Mandated Activity	NAGPRA	Section	1.00			1.00	1.00
Permit	Unit Price	Permit issuance costs (not billed)	PRMIT	Ea	121.00	748.14	-	90,524.94	90,524.94
Box	Unit Price	Curation of a 1' x 1' x 1' cubic box in perpetuity	BOXES	Ea	850.00	2,640.19	-	2,244,161.50	2,244,161.50
Files	Unit Price	Storage in perpetuity of 1 linear foot of paper files	FILES	Ft	525.00	2,263.13	-	1,188,143.25	1,188,143.25
					10,616.00			3,531,685.69	3,572,965.08

Section	Avg # Units	Avg inches/Unit	Total Inches / Year	Total ft / Year
Archiving	347	12	4,164	347
Survey Reg	306	4	1,224	102
Repatriation	114	8	912	76

525



List of Rates and Cost Pools

Cost Pools & Sub Accounts		
Pool ID	Sub Account for Cost Pool	Est. Pooled Costs
Environment	ENVIR	3,905.53
Equipment	EQPT	7,755.58
Office Supplies	SPPLY	5,007.97
Telecom	TELE	10,112.67
Desktop Computing Costs	SPPRT	10,425.43
Servers	SERVR	12,500.00
		49,707.18

UITS telecom charges for FTEs associated with mandated programs. /nbc

UITS desktop support charges for FTEs associated with mandated programs. /nbc

Annual cost from UITS for current server needs associated with State Mandated Programs. /nbc

Personnel

Person Name	Title	Primary Unit	Position Number	Direct Labor Empl?	Indirect Labor Apportionment Method	FTE	Annual Salary	Appt Type	Paid Holidays?	ERE Class	Non-Direct Labor Time	Direct Payroll	ERE Rate
			1980916	No	Utilization	1.00	82,608.00	Fiscal	Yes	Employee Full Benefit	2,088	0.00%	34.90%
	Assistant Librarian, Library Collections Manager	Library/Archives	2031913	Yes	Utilization	1.00	51,000.00	Fiscal	Yes	Employee Full Benefit	179	91.43%	34.90%
			2037369	No	Utilization	1.00	39,000.00	Fiscal	Yes	Employee Full Benefit	2,088	0.00%	34.90%
	Research Specialist	NAGPRA	2042187	Yes	Individual Direct L	0.50	43,639.20	Academic	Yes	Employee Full Benefit	0	100.00%	34.90%
	Curatorial/Museum Specialist	Arch Repository	1835348	Yes	Individual Direct L	1.00	32,245.00	Fiscal	Yes	Employee Full Benefit	0	100.00%	34.90%
			1926400	No	Utilization	0.38	20,880.00	Fiscal	Yes	Student Employees	2,088	0.00%	1.70%
			1863162	No	Utilization	1.00	59,999.00	Fiscal	Yes	Employee Full Benefit	2,088	0.00%	34.90%
			2041835	No	Utilization	1.00	77,000.00	Fiscal	Yes	Employee Full Benefit	2,088	0.00%	34.90%
			1851888	No	Utilization	0.48	32,071.68	Fiscal	Yes	Student Employees	2,088	0.00%	1.70%
	Undegrad Student Worker - Student Goup B		2033643	Yes	Individual Direct L	0.25	20,880.00	Fiscal	No	Student Employees	0	100.00%	1.70%
			1982516	Yes	Individual Direct L	0.25	20,880.00	Fiscal	Yes	Student Employees	0	100.00%	1.70%
	Assistant Curator, American Indian Relations	NAGPRA	1830695	Yes	Individual Direct L	1.00	64,607.00	Fiscal	Yes	Employee Full Benefit	0	100.00%	34.90%
			2001138	No	Utilization	1.00	31,000.00	Fiscal	Yes	Employee Full Benefit	2,088	0.00%	34.90%
			1865687	No	Utilization	1.00	60,000.00	Fiscal	Yes	Employee Full Benefit	2,088	0.00%	34.90%
	Curatorial/Museum Assistant	NAGPRA	2038429	Yes	Individual Direct L	1.00	22,968.00	Fiscal	Yes	Employee Full Benefit	0	100.00%	34.90%
	Associate Curator/Head of Collections	Collections	2028736	Yes	Utilization	1.00	82,000.00	Fiscal	Yes	Employee Full Benefit	36	98.28%	34.90%
	Curatorial/Museum Specialist	Arch Repository	1851463	Yes	Individual Direct L	1.00	35,369.00	Fiscal	Yes	Employee Full Benefit	0	100.00%	34.90%
			1864561	No	Utilization	1.00	59,480.00	Fiscal	Yes	Employee Full Benefit	2,088	0.00%	34.90%
	Curatorial/Museum Specialist, Sr	Archives/Registrar	2001187	Yes	Utilization	0.48	48,504.24	Fiscal	Yes	Classified Temporary	300	85.63%	13.70%
			2039660	No	Utilization	1.00	47,000.00	Fiscal	Yes	Employee Full Benefit	2,088	0.00%	34.90%
	Curatorial/Museum Assistant	NAGPRA	1849464	Yes	Individual Direct L	0.75	27,645.12	Fiscal	Yes	Employee Full Benefit	0	100.00%	34.90%
			1831143	Yes	Individual Direct L	0.38	27,144.00	Fiscal	Yes	Student Employees	0	100.00%	1.70%
	Librarian	Library/Archives	1902493	Yes	Utilization	1.00	84,051.00	Fiscal	Yes	Employee Full Benefit	358	82.85%	34.90%
	Administrator, Archaeological Geographic Information	Arch Records Office	2038993	Yes	Individual Direct L	1.00	52,200.00	Fiscal	Yes	Employee Full Benefit	0	100.00%	34.90%
			2043581	Yes	Individual Direct L	0.25	20,880.00	Fiscal	Yes	Student Employees	0	100.00%	1.70%
	Curatorial/Museum Specialist	Registrar	1809558	Yes	Utilization	1.00	34,434.00	Fiscal	Yes	Employee Full Benefit	36	98.28%	34.90%
			2035967	No	Utilization	1.00	50,000.00	Fiscal	Yes	Employee Full Benefit	2,088	0.00%	34.90%
	Library Specialist	Arch Records Office	1846079	Yes	Individual Direct L	1.00	32,090.00	Fiscal	Yes	Employee Full Benefit	0	100.00%	34.90%
			2037969	No	Utilization	0.88	33,908.00	Fiscal	Yes	Employee Full Benefit	2,088	0.00%	34.90%

Personnel

Person Name	Title	Primary Unit	Position Number	Direct Labor Empl?	Indirect Labor Apportionment Method	FTE	Annual Salary	Appt Type	Paid Holidays?	ERE Class	Non-Direct Labor Time	Direct Payroll	ERE Rate
			2032976	No	Utilization	0.25	20,880.00	Fiscal	Yes	Student Employees	2,088	0.00%	1.70%
			2016732	No	Utilization	1.00	62,150.00	Fiscal	Yes	Employee Full Benefit	2,088	0.00%	34.90%
	GRA	NAGPRA	1985732	Yes	Individual Direct L	0.25	33,000.00	Academic	Yes	Graduate Assistants	0	100.00%	13.40%
	Research Specialist, Principal	Research	2009196	Yes	Utilization	0.49	52,023.00	Fiscal	Yes	Classified Temporary	300	85.63%	13.70%
	Director, Finance & Administration	ORD	2042081	No	Utilization	1.00	91,800.00	Fiscal	Yes	Employee Full Benefit	2,088	0.00%	34.90%
			2035589	No	Utilization	0.80	21,924.00	Fiscal	Yes	Employee Full Benefit	2,088	0.00%	34.90%
			1971238	No	Utilization	0.38	27,144.00	Fiscal	Yes	Student Employees	2,088	0.00%	1.70%
			2042516	No	Utilization	1.00	52,869.00	Fiscal	Yes	Employee Full Benefit	2,088	0.00%	34.90%
			1922288	No	Utilization	0.30	20,880.00	Fiscal	Yes	Student Employees	2,088	0.00%	1.70%
	Director	ASM	2021347	Yes	Individual Direct L	1.00	124,373.00	Fiscal	Yes	Employee Full Benefit	0	100.00%	34.90%
	Research Specialist	NAGPRA	2038667	Yes	Individual Direct L	0.48	32,071.68	Fiscal	Yes	Employee Full Benefit	0	100.00%	34.90%
			2017922	No	Utilization	0.39	38,982.96	Fiscal	Yes	Classified Temporary	2,088	0.00%	13.70%
			2031936	No	Utilization	0.87	68,966.00	Fiscal	Yes	Employee Full Benefit	2,088	0.00%	34.90%
	Curatorial/Museum Specialist	Zoarch Collections	2040090	No	Utilization	0.50	43,451.28	Fiscal	Yes	Employee Full Benefit	2,088	0.00%	34.90%
			2036364	No	Utilization	0.38	20,880.00	Fiscal	Yes	Student Employees	2,088	0.00%	1.70%
	Lab Manager, Osteology	NAGPRA	1833996	Yes	Individual Direct L	1.00	54,005.00	Fiscal	Yes	Employee Full Benefit	0	100.00%	34.90%
			1979184	No	Utilization	0.03	31,000.00	Fiscal	Yes	Graduate Assistants	2,088	0.00%	13.40%
	Security Officer Supervisor		1829931	No	Utilization	1.00	36,638.00	Fiscal	Yes	Employee Full Benefit	2,088	0.00%	34.90%
	Associate Conservator	Preservation	1864562	No	Utilization	1.00	57,992.00	Fiscal	Yes	Employee Full Benefit	2,088	0.00%	34.90%
			1960054	Yes	Individual Direct L	1.00	92,392.00	Fiscal	Yes	Employee Full Benefit	0	100.00%	34.90%
	Associate Curator	State Repatriation/Per mits	2041836	Yes	Utilization	1.00	62,898.00	Fiscal	Yes	Employee Full Benefit	89	95.74%	34.90%
			2033509	No	Utilization	0.60	38,586.24	Fiscal	Yes	Employee Full Benefit	2,088	0.00%	34.90%
			2017099	No	Utilization	1.00	44,000.00	Fiscal	Yes	Employee Full Benefit	2,088	0.00%	34.90%
			1926144	No	Utilization	0.25	20,880.00	Fiscal	Yes	Student Employees	2,088	0.00%	1.70%
	Accountant, Senior		2042083	No	Utilization	1.00	42,408.00	Fiscal	Yes	Employee Full Benefit	2,088	0.00%	34.90%
			1927895	Yes	Individual Direct L	0.50	20,880.00	Fiscal	Yes	Student Employees	0	100.00%	1.70%
			1971235	No	Utilization	0.25	20,880.00	Fiscal	Yes	Student Employees	2,088	0.00%	1.70%
			1963416	No	Utilization	0.30	20,880.00	Fiscal	Yes	Student Employees	2,088	0.00%	1.70%
	Research Specialist	Arch Records Office	1800588	Yes	Utilization	0.63	43,996.00	Fiscal	Yes	Employee Full Benefit	304	85.44%	34.90%
			2012355	No	Utilization	1.00	82,600.00	Fiscal	Yes	Employee Full Benefit	2,088	0.00%	34.90%
	Manager, Archaeological Repository	Arch Repository	1831296	Yes	Individual Direct L	1.00	51,000.00	Fiscal	Yes	Employee Full Benefit	0	100.00%	34.90%
			2043526	No	Utilization	0.25	20,880.00	Fiscal	Yes	Student Employees	2,088	0.00%	1.70%
	Business Manager		2042085	No	Utilization	1.00	61,200.00	Fiscal	Yes	Employee Full Benefit	2,088	0.00%	34.90%
			2026703	No	Utilization	1.00	36,000.00	Fiscal	Yes	Employee Full Benefit	2,088	0.00%	34.90%
	Associate Curator	Bioarchaeology	1864485	Yes	Individual Direct L	1.00	64,607.00	Fiscal	Yes	Employee Full Benefit	0	100.00%	34.90%

Personnel

Person Name	Title	Primary Unit	Position Number	Direct Labor Empl?	Indirect Labor Apportionment Method	FTE	Annual Salary	Appt Type	Paid Holidays?	ERE Class	Non-Direct Labor Time	Direct Payroll	ERE Rate
	Curatorial/Museum Specialist, Senior	Photographic Colls	2003985	Yes	Utilization	1.00	48,489.00	Fiscal	Yes	Employee Full Benefit	72	96.55%	34.90%
			1854843	No	Utilization	0.50	37,584.00	Fiscal	Yes	Employee Full Benefit	2,088	0.00%	34.90%

People who are not direct labor employees, and who have their salary funded from the mandated programs account, or marked as subsidy, is allocated as Admin/Managerial/Security based on the relative utilization of each service.

Individuals who perform direct labor, but who also have managerial duties, only the time associated with their managerial duties has been listed in the Non-Direct Labor Time column. This causes the financial model to allocate the costs associated with the portion of their duties that are managerial as overhead across the rates in proportion to relative utilization while the costs of Vacation, Sick time & Holidays is allocated to the services for which they provide direct labor in proportion to their efforts amongst these activities.

Individuals highlighted in Red are no longer with the UA, but have been retained to provide an estimate of the cost of necessary replacement personnel. /nb

Total Payroll

Employee	Account	Sub Acct	Subsidy?	% Effort	Start Date	End Date	Appt Type	Annual Salary	FTE	Mandated FTE	Work Days	ERE Rate	Total Salary	Total ERE	Total Personnel	Direct Payroll	Indirect Payroll
	1145400	-	No	75.00%	7/1/16	6/30/17	Fiscal	82,608	1.00	0.00	261	34.9%	61,956.00	21,622.64	83,578.64	-	83,578.64
	1106900	-	No	25.00%	7/1/16	6/30/17	Fiscal	82,608	1.00	0.00	261	34.9%	20,652.00	7,207.55	27,859.55	-	27,859.55
	1145400	-	Yes	70.00%	7/1/16	6/30/17	Fiscal	51,000	1.00	0.70	261	34.9%	35,700.00	12,459.30	48,159.30	44,030.70	4,128.60
	1145400	-	No	30.00%	7/1/16	6/30/17	Fiscal	51,000	1.00	0.00	261	34.9%	15,300.00	5,339.70	20,639.70	18,870.30	1,769.40
	1145400	-	No	100.00%	7/1/16	6/30/17	Fiscal	39,000	1.00	0.00	261	34.9%	39,000.00	13,611.00	52,611.00	-	52,611.00
	1145400	-	Yes	100.00%	7/1/16	6/30/17	Fiscal	43,639	0.50	0.50	261	34.9%	21,819.60	7,615.04	29,434.64	29,434.64	-
	2121400	-	No	9.75%	7/1/16	6/30/17	Fiscal	32,245	1.00	0.00	261	34.9%	3,143.72	1,097.16	4,240.88	4,240.88	-
	2488800	-	No	50.00%	7/1/16	6/30/17	Fiscal	32,245	1.00	0.50	261	34.9%	16,123.16	5,626.98	21,750.14	21,750.14	-
	3015060	-	No	0.25%	7/1/16	6/30/17	Fiscal	32,245	1.00	0.00	261	34.9%	80.91	28.24	109.15	109.15	-
	3233903	-	No	40.00%	7/1/16	6/30/17	Fiscal	32,245	1.00	0.00	261	34.9%	12,897.21	4,501.13	17,398.34	17,398.34	-
	5503400	-	No	100.00%	7/1/16	6/30/17	Fiscal	20,880	0.38	0.00	261	1.7%	7,830.00	133.11	7,963.11	-	7,963.11
	1145400	-	No	100.00%	7/1/16	6/30/17	Fiscal	59,999	1.00	0.00	261	34.9%	59,999.00	20,939.65	80,938.65	-	80,938.65
	1145400	-	No	100.00%	7/1/16	6/30/17	Fiscal	77,000	1.00	0.00	261	34.9%	77,000.00	26,873.00	103,873.00	-	103,873.00
	3015060	-	No	100.00%	7/1/16	6/30/17	Fiscal	32,072	0.48	0.00	261	1.7%	15,394.41	261.70	15,656.11	-	15,656.11
	2488800	-	No	100.00%	7/1/16	6/30/17	Fiscal	20,880	0.25	0.00	251	1.7%	5,020.00	85.34	5,105.34	5,105.34	-
	2488800	-	No	100.00%	7/1/16	6/30/17	Fiscal	20,880	0.25	0.00	261	1.7%	5,220.00	88.74	5,308.74	5,308.74	-
	1145400	-	No	21.95%	7/1/16	6/30/17	Fiscal	64,607	1.00	0.00	261	34.9%	14,181.24	4,949.25	19,130.49	19,130.49	-
	1145400	-	Yes	20.00%	7/1/16	6/30/17	Fiscal	64,607	1.00	0.20	261	34.9%	12,921.40	4,509.57	17,430.97	17,430.97	-
	2110050	-	No	47.05%	7/1/16	6/30/17	Fiscal	64,607	1.00	0.00	261	34.9%	30,397.59	10,608.76	41,006.35	41,006.35	-
	2110050	-	No	0.98%	7/1/16	6/30/17	Fiscal	64,607	1.00	0.00	261	34.9%	633.15	220.97	854.12	854.12	-
	3012380	-	No	10.00%	7/1/16	6/30/17	Fiscal	64,607	1.00	0.00	261	34.9%	6,460.70	2,254.78	8,715.48	8,715.48	-
	3015060	-	No	0.02%	7/1/16	6/30/17	Fiscal	64,607	1.00	0.00	261	34.9%	12.92	4.51	17.43	17.43	-
	2219700	-	No	50.00%	7/1/16	6/30/17	Fiscal	31,000	1.00	0.00	261	34.9%	15,500.00	5,409.50	20,909.50	-	20,909.50
	2371400	-	No	50.00%	7/1/16	6/30/17	Fiscal	31,000	1.00	0.00	261	34.9%	15,500.00	5,409.50	20,909.50	-	20,909.50
	1145400	-	No	80.00%	7/1/16	6/30/17	Fiscal	60,000	1.00	0.00	261	34.9%	48,000.00	16,752.00	64,752.00	-	64,752.00
	3012380	-	No	20.00%	7/1/16	6/30/17	Fiscal	60,000	1.00	0.00	261	34.9%	12,000.00	4,188.00	16,188.00	-	16,188.00
	2121400	-	Yes	20.02%	7/1/16	6/30/17	Fiscal	22,968	1.00	0.20	261	34.9%	4,597.69	1,604.59	6,202.28	6,202.28	-
	3015060	-	No	4.98%	7/1/16	6/30/17	Fiscal	22,968	1.00	0.00	261	34.9%	1,144.33	399.37	1,543.70	1,543.70	-
	3233903	-	No	75.00%	7/1/16	6/30/17	Fiscal	22,968	1.00	0.00	261	34.9%	17,225.98	6,011.87	23,237.85	23,237.85	-
	1145400	-	No	79.00%	7/1/16	6/30/17	Fiscal	82,000	1.00	0.00	261	34.9%	64,780.00	22,608.22	87,388.22	85,881.53	1,506.69
	1145400	-	Yes	20.00%	7/1/16	6/30/17	Fiscal	82,000	1.00	0.20	261	34.9%	16,400.00	5,723.60	22,123.60	21,742.16	381.44
	2121400	-	No	0.98%	7/1/16	6/30/17	Fiscal	82,000	1.00	0.00	261	34.9%	803.60	280.46	1,084.06	1,065.37	18.69
	3015060	-	No	0.02%	7/1/16	6/30/17	Fiscal	82,000	1.00	0.00	261	34.9%	16.40	5.72	22.12	21.74	0.38
	2488800	-	No	100.00%	7/1/16	6/30/17	Fiscal	35,369	1.00	1.00	261	34.9%	35,369.00	12,343.78	47,712.78	47,712.78	-
	1145400	-	No	100.00%	7/1/16	6/30/17	Fiscal	59,480	1.00	0.00	261	34.9%	59,480.00	20,758.52	80,238.52	-	80,238.52
	2488800	-	No	100.00%	7/1/16	6/30/17	Fiscal	48,504	0.48	0.48	261	13.7%	23,282.04	3,189.64	26,471.68	22,668.28	3,803.40
	1145400	-	No	100.00%	7/1/16	6/30/17	Fiscal	47,000	1.00	0.00	261	34.9%	47,000.00	16,403.00	63,403.00	-	63,403.00
	2121400	-	Yes	97.50%	7/1/16	6/30/17	Fiscal	27,645	0.75	0.73	261	34.9%	20,215.49	7,055.21	27,270.70	27,270.70	-
	3015060	-	No	2.50%	7/1/16	6/30/17	Fiscal	27,645	0.75	0.00	261	34.9%	518.35	180.90	699.25	699.25	-
	5503400	-	No	100.00%	7/1/16	6/30/17	Fiscal	27,144	0.38	0.00	261	1.7%	10,179.00	173.04	10,352.04	10,352.04	-
	1145400	-	Yes	70.00%	7/1/16	6/30/17	Fiscal	84,051	1.00	0.70	261	34.9%	58,835.70	20,533.66	79,369.36	65,761.01	13,608.35
	1145400	-	No	30.00%	7/1/16	6/30/17	Fiscal	84,051	1.00	0.00	261	34.9%	25,215.30	8,800.14	34,015.44	28,183.29	5,832.15
	2488800	-	No	100.00%	7/1/16	6/30/17	Fiscal	52,200	1.00	1.00	261	34.9%	52,200.00	18,217.80	70,417.80	70,417.80	-
	5685420	-	No	100.00%	7/1/16	6/30/17	Fiscal	20,880	0.25	0.00	261	1.7%	5,220.00	88.74	5,308.74	5,308.74	-
	1145400	-	Yes	18.00%	7/1/16	6/30/17	Fiscal	34,434	1.00	0.18	261	34.9%	6,198.12	2,163.14	8,361.26	8,217.10	144.16
	1145400	-	No	82.00%	7/1/16	6/30/17	Fiscal	34,434	1.00	0.00	261	34.9%	28,235.88	9,854.32	38,090.20	37,433.47	656.73
	1145400	-	No	100.00%	7/1/16	6/30/17	Fiscal	50,000	1.00	0.00	261	34.9%	50,000.00	17,450.00	67,450.00	-	67,450.00
	2488800	-	No	100.00%	7/1/16	6/30/17	Fiscal	32,090	1.00	1.00	261	34.9%	32,090.00	11,199.41	43,289.41	43,289.41	-
	3012380	-	No	100.00%	7/1/16	6/30/17	Fiscal	33,908	0.88	0.00	261	34.9%	29,669.50	10,354.66	40,024.16	-	40,024.16
	2219700	-	No	100.00%	7/1/16	6/30/17	Fiscal	20,880	0.25	0.00	261	1.7%	5,220.00	88.74	5,308.74	-	5,308.74
	1145400	-	No	95.00%	7/1/16	6/30/17	Fiscal	62,150	1.00	0.00	261	34.9%	59,042.50	20,605.83	79,648.33	-	79,648.33

Total Payroll

Employee	Account	Sub Acct	Subsidy?	% Effort	Start Date	End Date	Appt Type	Annual Salary	FTE	Mandated FTE	Work Days	ERE Rate	Total Salary	Total ERE	Total Personnel	Direct Payroll	Indirect Payroll
	3011480	-	No	5.00%	7/1/16	6/30/17	Fiscal	62,150	1.00	0.00	261	34.9%	3,107.50	1,084.52	4,192.02	-	4,192.02
	1109110	-	Yes	100.00%	7/1/16	6/30/17	Fiscal	33,000	0.25	0.25	261	13.4%	8,250.00	1,105.50	9,355.50	9,355.50	-
	2488800	-	No	100.00%	7/1/16	6/30/17	Fiscal	52,023	0.49	0.49	261	13.7%	25,491.27	3,492.30	28,983.57	24,819.26	4,164.31
	1130013	-	No	10.00%	7/1/16	6/30/17	Fiscal	91,800	1.00	0.00	261	34.9%	9,180.00	3,203.82	12,383.82	-	12,383.82
	1130013	-	No	90.00%	7/1/16	6/30/17	Fiscal	91,800	1.00	0.00	261	34.9%	82,620.00	28,834.38	111,454.38	-	111,454.38
	1145400	-	No	100.00%	7/1/16	6/30/17	Fiscal	21,924	0.80	0.00	261	34.9%	17,539.20	6,121.18	23,660.38	-	23,660.38
	2255200	-	No	100.00%	7/1/16	6/30/17	Fiscal	27,144	0.38	0.00	261	1.7%	10,179.00	173.04	10,352.04	-	10,352.04
	1130014	-	No	27.00%	7/1/16	6/30/17	Fiscal	52,869	1.00	0.00	261	34.9%	14,274.63	4,981.85	19,256.48	-	19,256.48
	2113014	-	No	73.00%	7/1/16	6/30/17	Fiscal	52,869	1.00	0.00	261	34.9%	38,594.37	13,469.44	52,063.81	-	52,063.81
	1760800	-	No	100.00%	7/1/16	6/30/17	Fiscal	20,880	0.30	0.00	261	1.7%	6,264.00	106.49	6,370.49	-	6,370.49
	2110050	-	No	85.00%	7/1/16	6/30/17	Fiscal	124,373	1.00	0.00	261	34.9%	105,717.05	36,895.25	142,612.30	142,612.30	-
	2110050	-	Yes	10.00%	7/1/16	6/30/17	Fiscal	124,373	1.00	0.10	261	34.9%	12,437.30	4,340.62	16,777.92	16,777.92	-
	3012380	-	No	5.00%	7/1/16	6/30/17	Fiscal	124,373	1.00	0.00	261	34.9%	6,218.65	2,170.31	8,388.96	8,388.96	-
	3233903	-	Yes	95.00%	7/1/16	6/30/17	Fiscal	32,072	0.48	0.46	261	34.9%	14,624.69	5,104.02	19,728.71	19,728.71	-
	3233903	-	No	5.00%	7/1/16	6/30/17	Fiscal	32,072	0.48	0.00	261	34.9%	769.72	268.63	1,038.35	1,038.35	-
	3068000	-	No	100.00%	7/1/16	6/30/17	Fiscal	38,983	0.39	0.00	261	13.7%	15,203.35	2,082.86	17,286.21	-	17,286.21
	2103952	-	No	100.00%	7/1/16	6/30/17	Fiscal	68,966	0.87	0.00	261	34.9%	60,000.42	20,940.15	80,940.57	-	80,940.57
	1145400	-	No	100.00%	7/1/16	6/30/17	Fiscal	43,451	0.50	0.00	261	34.9%	21,725.64	7,582.25	29,307.89	-	29,307.89
	5503400	-	No	100.00%	7/1/16	6/30/17	Fiscal	20,880	0.38	0.00	261	1.7%	7,830.00	133.11	7,963.11	-	7,963.11
	1145400	-	Yes	55.00%	7/1/16	6/30/17	Fiscal	54,005	1.00	0.55	261	34.9%	29,702.75	10,366.26	40,069.01	40,069.01	-
	1145400	-	No	18.00%	7/1/16	6/30/17	Fiscal	54,005	1.00	0.00	261	34.9%	9,720.90	3,392.59	13,113.49	13,113.49	-
	2121400	-	No	5.85%	7/1/16	6/30/17	Fiscal	54,005	1.00	0.00	261	34.9%	3,159.29	1,102.59	4,261.88	4,261.88	-
	3015060	-	No	0.15%	7/1/16	6/30/17	Fiscal	54,005	1.00	0.00	261	34.9%	81.01	28.27	109.28	109.28	-
	3015630	-	No	21.00%	7/1/16	6/30/17	Fiscal	54,005	1.00	0.00	261	34.9%	11,341.05	3,958.03	15,299.08	15,299.08	-
	1106900	-	No	100.00%	7/1/16	6/30/17	Fiscal	31,000	0.03	0.00	261	13.4%	775.00	103.85	878.85	-	878.85
	1145400	-	Yes	50.00%	7/1/16	6/30/17	Fiscal	36,638	1.00	0.50	261	34.9%	18,319.00	6,393.33	24,712.33	-	24,712.33
	1145400	-	No	50.00%	7/1/16	6/30/17	Fiscal	36,638	1.00	0.00	261	34.9%	18,319.00	6,393.33	24,712.33	-	24,712.33
	1145400	-	No	75.00%	7/1/16	6/30/17	Fiscal	57,992	1.00	0.00	261	34.9%	43,494.00	15,179.41	58,673.41	-	58,673.41
	3011480	-	No	10.00%	7/1/16	6/30/17	Fiscal	57,992	1.00	0.00	261	34.9%	5,799.20	2,023.92	7,823.12	-	7,823.12
	3012380	-	No	15.00%	7/1/16	6/30/17	Fiscal	57,992	1.00	0.00	261	34.9%	8,698.80	3,035.88	11,734.68	-	11,734.68
	1145400	-	Yes	10.00%	7/1/16	6/30/17	Fiscal	92,392	1.00	0.10	261	34.9%	9,239.20	3,224.48	12,463.68	12,463.68	-
	1145400	-	No	74.47%	7/1/16	6/30/17	Fiscal	92,392	1.00	0.00	261	34.9%	68,800.92	24,011.52	92,812.44	92,812.44	-
	3012380	-	No	15.53%	7/1/16	6/30/17	Fiscal	92,392	1.00	0.00	261	34.9%	14,351.88	5,008.81	19,360.69	19,360.69	-
	1145400	-	Yes	65.00%	7/1/16	6/30/17	Fiscal	62,898	1.00	0.65	261	34.9%	40,883.70	14,268.41	55,152.11	52,801.28	2,350.83
	1145400	-	No	35.00%	7/1/16	6/30/17	Fiscal	62,898	1.00	0.00	261	34.9%	22,014.30	7,682.99	29,697.29	28,431.46	1,265.83
	3012380	-	No	100.00%	7/1/16	6/30/17	Fiscal	38,586	0.60	0.00	261	34.9%	23,151.74	8,079.96	31,231.70	-	31,231.70
	1760800	-	No	100.00%	7/1/16	6/30/17	Fiscal	44,000	1.00	0.00	261	34.9%	44,000.00	15,356.00	59,356.00	-	59,356.00
	3018040	-	No	100.00%	7/1/16	6/30/17	Fiscal	20,880	0.25	0.00	261	1.7%	5,220.00	88.74	5,308.74	-	5,308.74
	1130013	-	Yes	80.00%	7/1/16	6/30/17	Fiscal	42,408	1.00	0.80	261	34.9%	33,926.40	11,840.31	45,766.71	-	45,766.71
	1130013	-	No	20.00%	7/1/16	6/30/17	Fiscal	42,408	1.00	0.00	261	34.9%	8,481.60	2,960.08	11,441.68	-	11,441.68
	2488800	-	No	100.00%	7/1/16	6/30/17	Fiscal	20,880	0.50	0.00	261	1.7%	10,440.00	177.48	10,617.48	10,617.48	-
	3018040	-	No	100.00%	7/1/16	6/30/17	Fiscal	20,880	0.25	0.00	261	1.7%	5,220.00	88.74	5,308.74	-	5,308.74
	5559000	-	No	100.00%	7/1/16	6/30/17	Fiscal	20,880	0.30	0.00	261	1.7%	6,264.00	106.49	6,370.49	-	6,370.49
	1145400	-	Yes	94.34%	7/1/16	6/30/17	Fiscal	43,996	0.63	0.59	261	34.9%	26,148.67	9,125.89	35,274.56	30,138.80	5,135.76
	1145400	-	No	5.66%	7/1/16	6/30/17	Fiscal	43,996	0.63	0.00	261	34.9%	1,568.81	547.51	2,116.32	1,808.20	308.12
	2554003	-	No	50.00%	7/1/16	6/30/17	Fiscal	82,600	1.00	0.00	261	34.9%	41,300.00	14,413.70	55,713.70	-	55,713.70
	1145400	-	No	50.00%	7/1/16	6/30/17	Fiscal	82,600	1.00	0.00	261	34.9%	41,300.00	14,413.70	55,713.70	-	55,713.70
	1145400	-	Yes	37.00%	7/1/16	6/30/17	Fiscal	51,000	1.00	0.37	261	34.9%	18,870.00	6,585.63	25,455.63	25,455.63	-
	2488800	-	No	58.00%	7/1/16	6/30/17	Fiscal	51,000	1.00	0.58	261	34.9%	29,580.00	10,323.42	39,903.42	39,903.42	-
	1145400	-	No	5.00%	7/1/16	6/30/17	Fiscal	51,000	1.00	0.00	261	34.9%	2,550.00	889.95	3,439.95	3,439.95	-
	5580600	-	No	100.00%	7/1/16	6/30/17	Fiscal	20,880	0.25	0.00	261	1.7%	5,220.00	88.74	5,308.74	-	5,308.74

Total Payroll

Employee	Account	Sub Acct	Subsidy?	% Effort	Start Date	End Date	Appt Type	Annual Salary	FTE	Mandated FTE	Work Days	ERE Rate	Total Salary	Total ERE	Total Personnel	Direct Payroll	Indirect Payroll
	1130013	-	No	10.00%	7/1/16	6/30/17	Fiscal	61,200	1.00	0.00	261	34.9%	6,120.00	2,135.88	8,255.88	-	8,255.88
	1130013	-	No	90.00%	7/1/16	6/30/17	Fiscal	61,200	1.00	0.00	261	34.9%	55,080.00	19,222.92	74,302.92	-	74,302.92
	1145400	-	No	100.00%	7/1/16	6/30/17	Fiscal	36,000	1.00	0.00	261	34.9%	36,000.00	12,564.00	48,564.00	-	48,564.00
	1145400	-	Yes	10.00%	7/1/16	6/30/17	Fiscal	64,607	1.00	0.10	261	34.9%	6,460.70	2,254.78	8,715.48	8,715.48	-
	1145400	-	No	90.00%	7/1/16	6/30/17	Fiscal	64,607	1.00	0.00	261	34.9%	58,146.30	20,293.06	78,439.36	78,439.36	-
	1145400	-	Yes	10.00%	7/1/16	6/30/17	Fiscal	48,489	1.00	0.10	261	34.9%	4,848.90	1,692.27	6,541.17	6,315.61	225.56
	1145400	-	No	80.00%	7/1/16	6/30/17	Fiscal	48,489	1.00	0.00	261	34.9%	38,791.20	13,538.13	52,329.33	50,524.87	1,804.46
	3011480	-	No	10.00%	7/1/16	6/30/17	Fiscal	48,489	1.00	0.00	261	34.9%	4,848.90	1,692.27	6,541.17	6,315.61	225.56
	5685420	-	No	100.00%	7/1/16	6/30/17	Fiscal	37,584	0.50	0.00	261	34.9%	18,792.00	6,558.41	25,350.41	-	25,350.41
										13.03			2,502,737.90	821,192.93	3,323,930.83	1,503,529.27	1,820,401.56

Lines with the service center's account and subsidy listed as "No" will be Green with Green font. No Review of these lines is necessary.

Lines with the service center's account and subsidy listed as "Yes" will be Red with Red font. To correct either make the subsidy field read "No" or change the account number.

Lines with a non-service center account and subsidy listed as "No" will have no fill and font will remain black. Review these lines to ensure that they are not subsidization of the rates.

Lines with a non-service center account and subsidy listed as "Yes" will have Yellow fill and Yellow font. Review these lines to ensure that they are in fact subsidization of the rates.

Direct Payroll and Subsidy Apportionment

Employee	Rate ID	Effort	Direct Payroll Allowable	Direct Payroll Apportioned	Indirect Payroll Apportioned	Direct Payroll Subsidy Allowable	Direct Payroll Subsidy Apportioned	Indirect Payroll Subsidy Apportioned
	Specialist	100.00%	-	-	-	44,030.70	44,030.70	-
	NAGPRA	100.00%	-	-	-	29,434.64	29,434.64	-
	NAGPRA	84.21%	21,750.14	18,315.91	-	-	-	-
	Specialist	15.79%	21,750.14	3,434.23	-	-	-	-
	AZSite	33.33%	5,105.34	1,701.78	-	-	-	-
	Assistants	66.67%	5,105.34	3,403.56	-	-	-	-
	NAGPRA	100.00%	-	-	-	17,430.97	17,430.97	-
	NAGPRA	100.00%	-	-	-	6,202.28	6,202.28	-
	Professional	100.00%	-	-	-	21,742.16	21,742.16	-
	Specialist	100.00%	47,712.78	47,712.78	-	-	-	-
	NAGPRA	100.00%	-	-	-	27,270.70	27,270.70	-
	Professional	100.00%	-	-	-	65,761.01	65,761.01	-
	Specialist	44.44%	70,417.80	31,296.80	-	-	-	-
	AZSite	55.56%	70,417.80	39,121.00	-	-	-	-
	Specialist	44.44%	-	-	-	8,217.10	3,652.04	-
	NAGPRA	55.56%	-	-	-	8,217.10	4,565.06	-
	Specialist	88.24%	43,289.41	38,196.54	-	-	-	-
	AZSite	11.76%	43,289.41	5,092.87	-	-	-	-
	Specialist	100.00%	-	-	-	9,355.50	9,355.50	-
	NAGPRA	94.74%	-	-	-	19,728.71	18,690.36	-
	Specialist	5.26%	-	-	-	19,728.71	1,038.35	-
	NAGPRA	100.00%	-	-	-	40,069.01	40,069.01	-
	Professional	100.00%	-	-	-	12,463.68	12,463.68	-
	AZSite	10.77%	-	-	-	52,801.28	5,686.29	-
	Professional	35.38%	-	-	-	52,801.28	18,683.53	-
	Permit	53.85%	-	-	-	52,801.28	28,431.46	-
	Specialist	18.00%	-	-	-	30,138.80	5,424.98	-
	Permit	82.00%	-	-	-	30,138.80	24,713.82	-
	Specialist	68.42%	39,903.42	27,302.34	-	25,455.63	17,417.01	-
	NAGPRA	31.58%	39,903.42	12,601.08	-	25,455.63	8,038.62	-
	AZSite	10.00%	-	-	-	8,715.48	871.55	-
	NAGPRA	60.00%	-	-	-	8,715.48	5,229.29	-

Direct Payroll and Subsidy Apportionment

Employee	Rate ID	Effort	Direct Payroll Allowable	Direct Payroll Apportioned	Indirect Payroll Apportioned	Direct Payroll Subsidy Allowable	Direct Payroll Subsidy Apportioned	Indirect Payroll Subsidy Apportioned
	Professional	30.00%	-	-	-	8,715.48	2,614.64	-
	Specialist	40.00%	-	-	-	6,315.61	2,526.24	-
	NAGPRA	60.00%	-	-	-	6,315.61	3,789.37	-
	AZSite	33.33%	5,308.74	1,769.58	-	-	-	-
	Assistants	66.67%	5,308.74	3,539.16	-	-	-	-
	AZSite	33.33%	10,617.48	3,539.16	-	-	-	-
	Assistants	66.67%	10,617.48	7,078.32	-	-	-	-
	Assistants	16.69%	-	-	-	16,777.92	2,800.70	-
	Specialist	63.17%	-	-	-	16,777.92	10,598.88	-
	Professional	16.12%	-	-	-	16,777.92	2,704.42	-
	AZSite	2.75%	-	-	-	16,777.92	462.11	-
	Permit	1.26%	-	-	-	16,777.92	211.80	-
	Specialist	100.00%	22,668.28	22,668.28	-	-	-	-
	Specialist	100.00%	24,819.26	24,819.26	-	-	-	-
		2700.00%		291,592.65	-	721,912.23	441,911.18	-
			Direct Salary Allowed	291,592.65		Subsidy Allowed	441,911.18	
			Direct Salary Allowable	291,592.65		Subsidy Allowable	441,911.18	
			Variance	-		Variance	-	

Operational Cost Apportionment

Pool ID	Rate ID	Cost Category	Usage	Apportionment %	Est. Pooled Costs	Apportioned Cost
Telecom	Assistants	General Expenses	7.80%	13.58%	10,112.67	1,373.53
Telecom	Specialist	General Expenses	37.62%	65.53%	10,112.67	6,626.86
Telecom	Professional	General Expenses	9.60%	16.72%	10,112.67	1,690.92
Telecom	AZSite	General Expenses	1.64%	2.86%	10,112.67	288.93
Telecom	Permit	General Expenses	0.75%	1.31%	10,112.67	132.43
Desktop Computing Costs	Assistants	General Expenses	7.80%	13.58%	10,425.43	1,416.01
Desktop Computing Costs	Specialist	General Expenses	37.62%	65.53%	10,425.43	6,831.82
Desktop Computing Costs	Professional	General Expenses	9.60%	16.72%	10,425.43	1,743.21
Desktop Computing Costs	AZSite	General Expenses	1.64%	2.86%	10,425.43	297.87
Desktop Computing Costs	Permit	General Expenses	0.75%	1.31%	10,425.43	136.52
Servers	Assistants	General Expenses	7.80%	13.58%	12,500.00	1,697.78
Servers	Specialist	General Expenses	37.62%	65.53%	12,500.00	8,191.29
Servers	Professional	General Expenses	9.60%	16.72%	12,500.00	2,090.10
Servers	AZSite	General Expenses	1.64%	2.86%	12,500.00	357.14
Servers	Permit	General Expenses	0.75%	1.31%	12,500.00	163.69
Equipment	Assistants	General Expenses	7.80%	13.58%	7,755.58	1,053.38
Equipment	Specialist	General Expenses	37.62%	65.53%	7,755.58	5,082.26
Equipment	Professional	General Expenses	9.60%	16.72%	7,755.58	1,296.79
Equipment	AZSite	General Expenses	1.64%	2.86%	7,755.58	221.59
Equipment	Permit	General Expenses	0.75%	1.31%	7,755.58	101.56
Office Supplies	Assistants	General Expenses	7.80%	13.58%	5,007.97	680.20
Office Supplies	Specialist	General Expenses	37.62%	65.53%	5,007.97	3,281.74
Office Supplies	Professional	General Expenses	9.60%	16.72%	5,007.97	837.37
Office Supplies	AZSite	General Expenses	1.64%	2.86%	5,007.97	143.08
Office Supplies	Permit	General Expenses	0.75%	1.31%	5,007.97	65.58
Environment	Box	General Expenses	5.28%	61.82%	3,905.53	2,414.33
Environment	Files	General Expenses	3.26%	38.18%	3,905.53	1,491.20
						49,707.18
					Direct Operational Costs Allowed	3,572,965.08
					Operational Subsidy Allowed	-
					Total Operational Costs Allowed	3,622,672.26
					Total Operational Costs Allowable	3,622,672.26
					Variance	-

Rates

Rate ID	Name of Service	Direct Payroll	Direct Payroll Subsidy	Indirect Payroll	Indirect Payroll Subsidy	Total Direct Operational Costs	Indirect Operational
Assistants	Per hour charge for basic services provided.	14,021.04	2,800.70	621.26	11,402.55	1,255.00	6,220.90
Specialist	Per hour charge for specialist services provided.	195,430.23	94,043.72	2,997.39	55,013.88	6,055.00	30,013.96
Professional	Per hour charge for professional services provided.	-	123,969.45	764.82	14,037.40	1,545.00	7,658.39
AZSite	Annual Subscription to AZSite Database	51,224.39	7,019.95	130.69	2,398.62	41,279.39	1,308.62
NAGPRA	Federally Mandated Activity	30,916.99	160,720.29	2,713.00	9.09	1.00	-
Permit	Permit issuance costs (not billed)	-	53,357.08	59.90	1,099.37	90,524.94	599.78
Box	Curation of a 1' x 1' x 1' cubic box in perpetuity	-	-	420.77	7,722.84	2,244,161.50	2,414.33
Files	Storage in perpetuity of 1 linear foot of paper files	-	-	259.89	4,769.99	1,188,143.25	1,491.20
		291,592.65	441,911.18	7,967.71	96,453.74	3,572,965.08	49,707.18
	Total Allowed	291,592.65	441,911.18	7,967.71	96,453.74		3,622,672.26
	Less: Subsidized Expense						-
	Direct Expense						3,572,965.08
	Indirect Expense						49,707.18
	Total Allowable	291,592.65	441,911.18	7,967.71	96,453.74		3,622,672.26
	Variance	-	-	-	-		-

* Because Operations, Maintenance, Utilities Debt Payments are included within the \$25.19 per net assignable square foot of costs in the RCM model, these percentages are removed from the Box and Files rates to prevent double charging. /nbc

Rates

Rate ID	Name of Service	Subtotal	Space, Utilities, Operations, Maintenance, Interest & General Administration	Total Cost	Minimum Rate	Unit Base
Assistants	Per hour charge for basic services provided.	36,321.44	6,537.86	42,859.30	37.74	Hr
Specialist	Per hour charge for specialist services provided.	383,554.19	69,039.75	452,593.94	82.59	Hr
Professional	Per hour charge for professional services provided.	147,975.05	26,635.51	174,610.56	124.88	Hr
AZSite	Annual Subscription to AZSite Database	103,361.66	18,605.10	121,966.76	510.49	Ea
NAGPRA	Federally Mandated Activity	194,360.36	34,984.86	229,345.22	253,420.13	Section
Permit	Permit issuance costs (not billed)	145,641.07	26,215.39	171,856.46	1,569.39	Ea
Box	Curation of a 1' x 1' x 1' cubic box in perpetuity	2,254,719.44	56,367.99	2,311,087.43	3,004.34	Ea *
Files	Storage in perpetuity of 1 linear foot of paper files	1,194,664.33	29,866.61	1,224,530.94	2,577.28	Ft *
		4,460,597.54	268,253.07	4,728,850.61		

Total Allowed
Less: Subsidized Expense
Direct Expense
Indirect Expense
Total Allowable
Variance

* Because Operations, Maintenance, Utilities Debt Payments are included within the \$25.19 per net assignable square foot of costs in the RCM model, these percentages are removed from the Box and Files rates to prevent double charging. /nbc



The University of Arizona
PURCHASE ORDER

PO Number: 327462
Contract Manager: Gloria Zimmerschied

Vendor INTERIOR SOLUTIONS OF ARIZONA LLC 4645 S 35TH STREET PHOENIX, AZ 85040		Shipping Address Arthur Vokes ARIZONA STATE MUSEUM SOUTH , Route Code :TB , Room #106-108 1010 E University Blvd TUCSON, AZ 85719 UNITED STATES	
Shipping Terms PREPAID AND ADD - ORIGIN (VENDOR LOCATION)		Payment Terms Net 30 Days	
Delivery Required By			
Order Date 06-24-2016	Customer #		Billing Address The University of Arizona Accounts Payable 1303 E University Blvd., Box 5 Tucson, AZ 85719-0521 520-621-9097 Invoice status inquiry: accts_pay@fso.arizona.edu; fax invoices to 520-626-1243 or email invoices to invoices@fso.arizona.edu
Delivery Instructions	Contract ID		

Vendor Note(s)
EMAIL: sales@interiorsolutions.net
QUOTE # 34591
STATE CONTRACT # ADSP013-040686
*
EMAIL ORDER CONFIRMATION: gloriаз@email.arizona.edu

Vendor Stipulations and Information
* VENDOR: PLEASE FILL ORDER AS EMAILED. PAPER COPY WILL NOT BE MAILED.

Item No.	Quantity	UOM	Description	Unit Cost	Extended Cost	Tax Amount	Total Amount
1	1.00	EA	Spacesaver Mechanical Assist System to include (8) Carriages, (2) Runs of Stationary Shelving with 4-Post Back-to-Back Shelving and (16) Aisle Lights - Quote # 34591	76494.1000	\$76,494.10	\$6,196.02	\$82,690.12
2	1.00	EA	Floor, Ramp and HPLF Panels - Quote # 34591	13107.0000	\$13,107.00	\$1,061.67	\$14,168.67
3			Labor to Install During Regular Business Hours - 489 hours @ \$37 per hour - Quote # 34591	18093.0000	\$18,093.00	\$0.00	\$18,093.00
4			Design Services - 8 hours @ \$50 per hour - Quote # 34591	400.0000	\$400.00	\$0.00	\$400.00
			FREIGHT - Delivery - Quote # 34591	7122.4100	\$7,122.41	\$0.00	\$7,122.41
					Total Prior to Tax:		\$115,216.51
					Estimated Tax:		\$7,257.69
					Total order amount:		\$122,474.20

8.1% rate for future estimates. /nbc

- 1 Vendor Instructions:
1. Acceptance of this order includes acceptance of all conditions on face and back.
 2. Price increases will not be recognized without written notice and acceptance by Purchasing.
 3. Please itemize all charges on your invoice and reference the PO number.
 4. University is exempt from federal excise tax. Certificate of registry is A-184524.
 5. Transaction privilege tax no. 20221243.
 6. Out of state vendors charging Arizona sales tax must show permit number.



The University of Arizona
PURCHASE ORDER

PO Number: 327462

Contract Manager: Gloria Zimmerschied

7. For invoicing and payment information contact Accounts Payable at address above or at accts_pay@fso.arizona.edu. Fax invoices to 520-626-1243 or email invoices to invoices@fso.arizona.edu.

EDWARD D NASSER
DIRECTOR OF PURCHASING

Buyer Signature / Initials

Gloria Zimmerschied 520-626-7926

Interior Solutions of Arizona, LLC
 4645 S. 35th Street
 Phoenix, AZ 85040
 Phone: (480) 413-9626
 Fax: (480) 413-9656
 http://www.interiorsolutions.net



Invoice # 105576-1-MB
Type Final
Job # 105576

Bill To

The University of Arizona
 Arizona State Museum
 1013 East University Blvd.
 PO Box 210026
 Tucson, AZ 85719

Install To

The University of Arizona
 Arizona State Museum
 1013 East University Blvd.
 PO Box 210026
 Tucson, AZ 85719

CUSTOMER PO	SALESPERSON	TERMS	INVOICE DATE	DUE DATE			
327462	Rick Contryman	Net 30	9/21/2016	10/21/2016			
ARIZONA STATE MUSEUM - BOX STORAGE							
LINE	PART #	DESCRIPTION	QTY	B.O.	UNIT	PRICE EA	EXT PRICE
1	LOT	SPACESAVER MECHANICAL ASSIST SYSTEM TO INCLUDE (8) CARRIAGES, (2) RUNS OF STATIONARY SHELVING WITH 4-POST BACK-TO-BACK SHELVING AND (16) AISLE LIGHTS	1.00	0.00	EA	\$76,494.10	\$76,494.10
		FINISH : FROST					
2	INSTALL	LABOR TO INSTALL DURING REGULAR BUSINESS HOURS	489.00	0.00	EA	\$37.00	\$18,093.00
3	DELIVERY	DELIVERY	1.00	0.00	EA	\$7,122.41	\$7,122.41
4	FAB	FLOOR, RAMP, AND HPLF PANELS LAMINATE : AGED PAIZZA	1.00	0.00	EA	\$13,107.00	\$13,107.00
5	DESIGN	DESIGN SERVICES	8.00	0.00	EA	\$50.00	\$400.00
Subtotal						\$115,216.51	
Tax						\$7,257.69	
Order Total						\$122,474.20	

Thank you for your business!

Amount Previously Invoiced	\$0.00
Payments	\$0.00
100.00 % Billing	\$115,216.51
Tax	\$7,257.69
Subtotal	\$122,474.20
Credits / Discounts	\$0.00
Amount Due	\$122,474.20

Comes to \$15,309.275 per carriage (8 carriages). /nbc





Wednesday, June 22, 2016
Quote Number: 34591

Arthur W. Vokes
Arizona State Museum
The University of Arizona
P.O. Box 210026
Tucson, Arizona 85271

Subject: Spacesaver High Density Mobile storage system.
Additional carriage cost.

Dear Dr. Vokes,

This is for the large room, which is in the basement of the old building. There is room to add nine (9) more carriages to this system. The track, floor, and ramp is already installed.

BUDGET COST TO ADD ONE CARRIAGE: \$14,135.00

Comes to \$15,279.935 per carriage after tax of 8.1%. /nbc

The above budget figure is for one complete carriage, to include shelving, face panel, and lights, delivered and installed, but does not include sales tax or any bonding costs.

All installation would be done with our factory trained personnel. Our Arizona Contractor's license number is ROC183388.

Thank you for this opportunity to be of service and we look forward to working with you on this project.

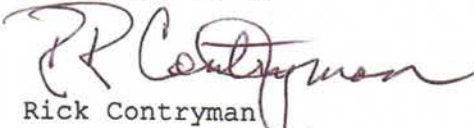
Sincerely Yours

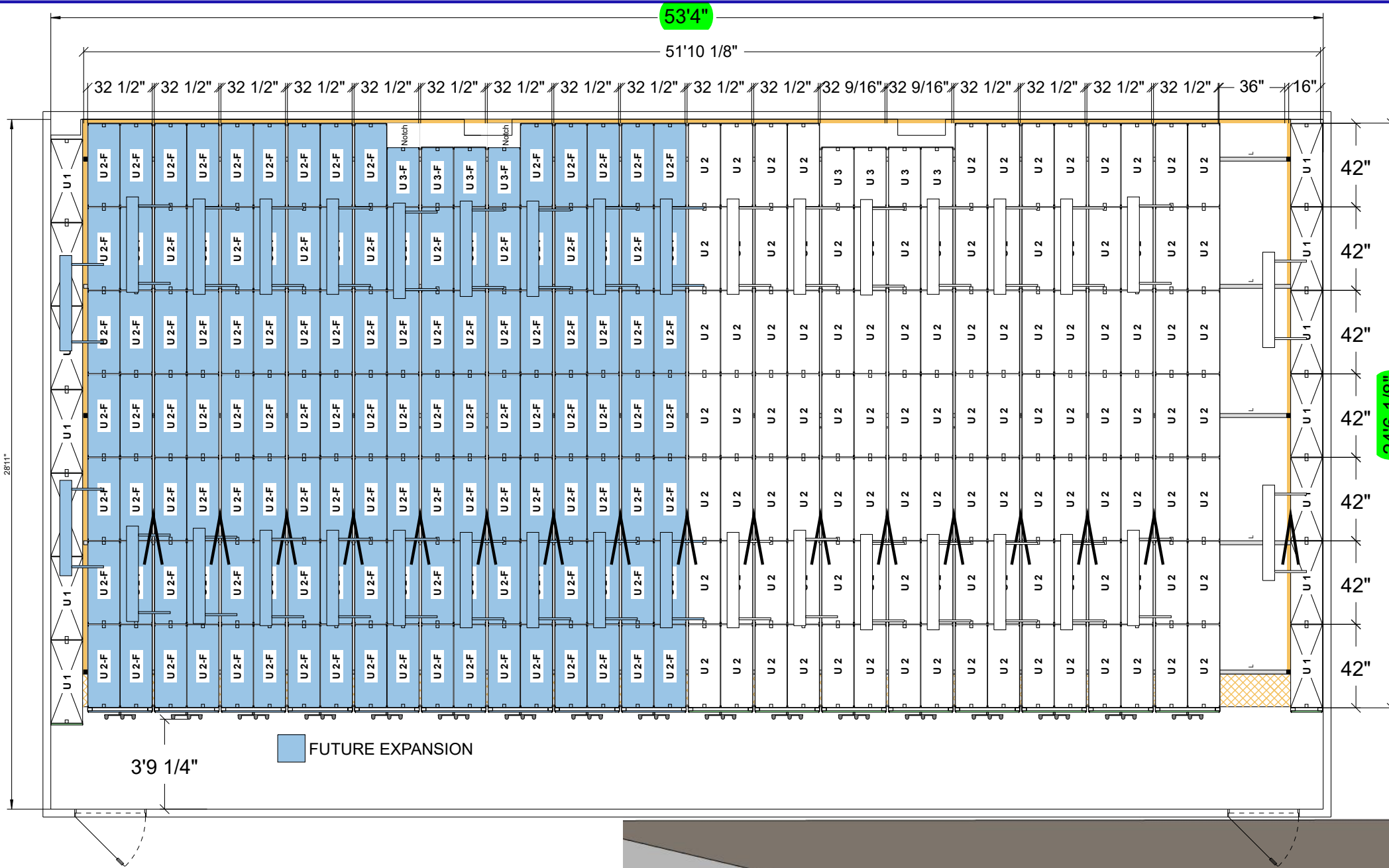
Rick Contryman



1,305.85 square feet for this storage system (53.3' x 24.5').
 At maximum efficiency this system provides 1 archive box storage per 0.2167026 square foot of space. At 80% efficiency this comes to 0.270878277 square feet per box.

SYSTEM CAPACITIES

- FIXED RANGES =**
- (378) ARCHIVE STORAGE BOXES PER LONG CARRIAGES =**
- (336) ARCHIVE STORAGE BOXES PER SHORT CARRIAGES =**
- (320) ARCHIVE STORAGE BOXES PER NOTCHED CARRIAGES =**
- (328) ARCHIVE STORAGE BOXES**

TOTAL SYSTEM = (6,026) ARCHIVE BOXES

Paint Finish: Frost
 Laminate Finish: Aged Piazza

Maximum capacity (i.e. maximum efficiency).

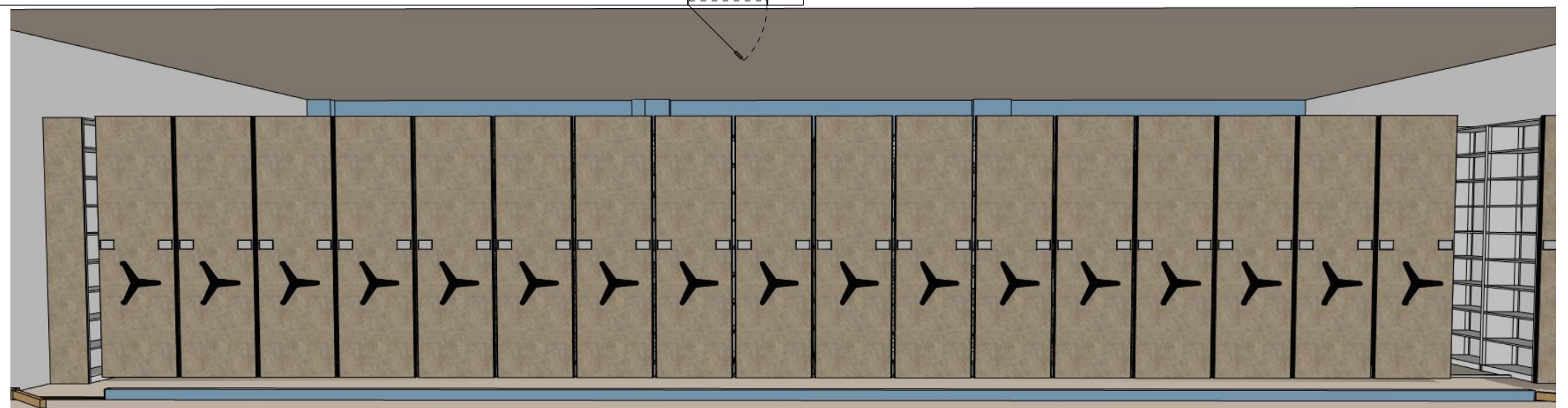
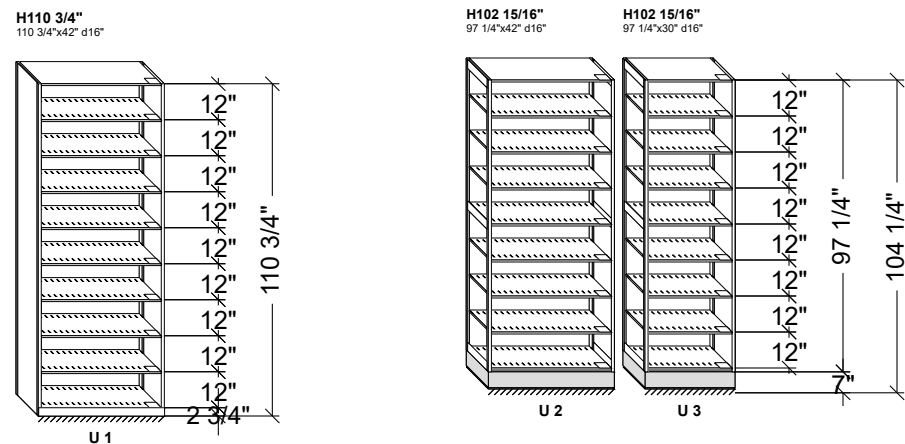

Project Name: ARIZONA STATE MUSEUM - ONE AISLE ARCHIVE STORAGE

Salesperson:
CONTRYMAN, RICK

Scale
 3/16" = 1'

Rev level:

Project #: 105576
 Drawn by: Rick Contryman
 Date Printed: 06/27/2016

APPROVAL
 This drawing Approved By: _____
 Dated: _____

Facilities Rate

Facilities cost which includes operations, maintenance, utilities, and debt payments associated with facilities and grounds are recovered by charging a flat rate charged per square foot on all space that is assigned to a unit. At the outset of RCM these costs have been initially funded through subvention funds provided to the Revenue RCUs. The cost of facilities is also a component of Support RCU total cost. These facilities costs do not include service which have previously been billed back to units. These billable services will continue to be billed to units separately.

Facilities are being charged based on the space that has been assigned to units. If a unit increases the amount of space they have they will be billed for the additional space, or if they decrease their space they will reduce their cost. If the total overall cost of facilities goes up the rate charged will increase. The rate is calculated by taking the total overall cost of facilities for the university and dividing it by the amount of square feet that are assigned to units. The rate for FY16 is \$25.19 per Net Assignable Square Foot (NASF).

Support Center Expense Recovery

The recovery of support RCU expenses are funded through assessments to the revenue allocated to Revenue RCUs and the amount of subvention received by the Revenue RCUs. An assessment rate has been determined using the FY15 base budget that is applied to Revenues and Subventions within the model that will recover the support RCU costs. The support unit expense recovery rate will stay stable for 3 years and is scheduled to be reviewed every 3 years.

University support functions are funded through a tax on revenues and subventions. Each type of revenue allocated to revenue RCUs is taxed at a separate rate.

If the tax rate for undergraduate tuition is determined to be 31% and the strategic investment rate is 1.7%, each dollar allocated for undergraduate activity will be assessed 32.7%. This would mean that for each \$100 allocated of undergraduate revenue, \$77.30 will be distributed to the College and \$31.00 will be held to fund university support costs and \$1.70 will be applied the Strategic Investment Fund.

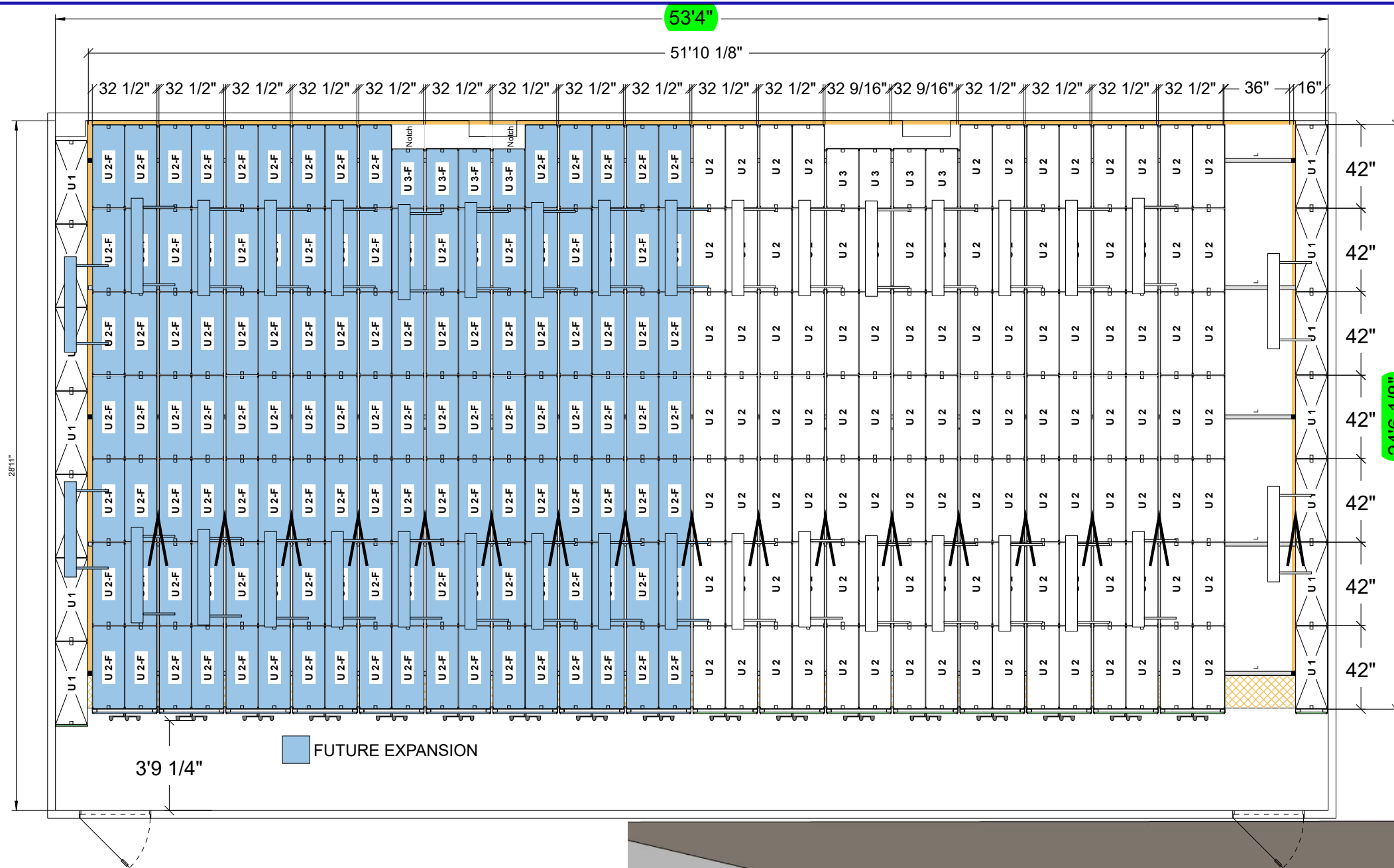

1,305.85 square feet for this storage system (53.3' x 24.5').
 At maximum efficiency this system provides 1 archive box storage per 0.2167026 square foot of space. At 80% efficiency this comes to 0.270878277 square feet per box.

SYSTEM CAPACITIES

- FIXED RANGES =**
- (378) ARCHIVE STORAGE BOXES PER LONG CARRIAGES =**
- (336) ARCHIVE STORAGE BOXES PER SHORT CARRIAGES =**
- (320) ARCHIVE STORAGE BOXES PER NOTCHED CARRIAGES =**
- (328) ARCHIVE STORAGE BOXES**

TOTAL SYSTEM = (6,026) ARCHIVE BOXES

Paint Finish: Frost
 Laminate Finish: Aged Piazza
 Maximum capacity (i.e. maximum efficiency).

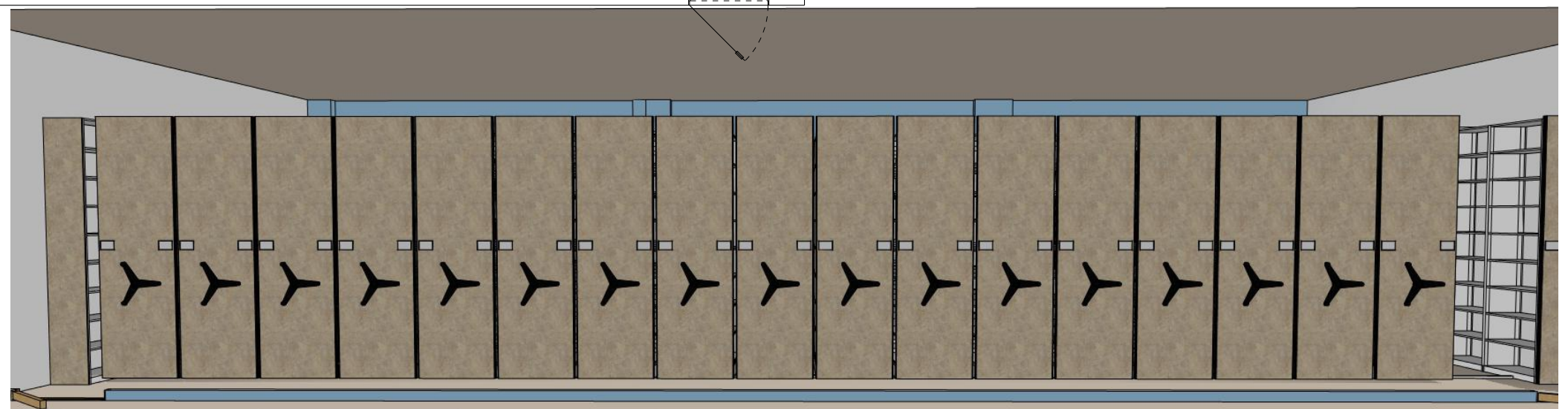
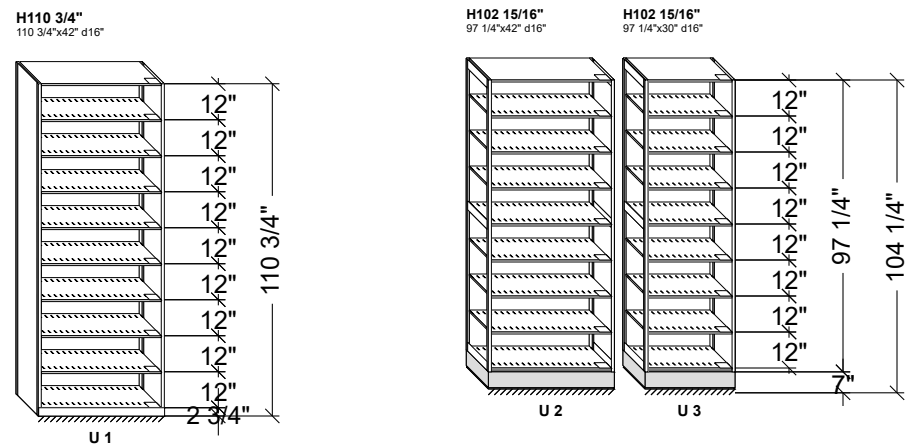

Project Name: ARIZONA STATE MUSEUM - ONE AISLE ARCHIVE STORAGE

Salesperson: CONTRYMAN, RICK

Scale: 3/16" = 1'

Rev level:

Project #: 105576
 Drawn by: Rick Contryman
 Date Printed: 06/27/2016

APPROVAL
 This drawing Approved By: _____
 Dated: _____



[IT Support](#) | [UIITS Staff](#) | [Contact UIITS](#)

[UIITS Support & Resources](#) [Services](#) [Locations & Hours](#) [News & Events](#) [About UIITS](#)

[UIITS Home](#) » [Content](#) » [Desktop or Workstation Computer Support](#)

Desktop or Workstation Computer Support

Workstation support services are provided to campus departments. Basic phone support is provided free while more in-depth assistance is provided to the campus through annual pay-for-service agreements or on a per-project basis.

- **Knowledgeable, personalized support**
Each department is assigned WNC analysts who become familiar with your environment and your department's unique requirements. You can be assured that your service requests will be responded to in a timely manner by our knowledgeable staff. Our analysts have over 100 years of combined computer support experience.
- **Integrated desktop/server management**
WNC analysts manage your desktop computers to ensure stable and secure computing. We provide centralized installation and automatic upgrades and patches for anti-virus software, anti-spyware software, operating systems, and application software.
- **Data protection**
We provide an infrastructure of servers which allow departments to store and share their data files. Data stored on the servers is backed up frequently and housed off-site in a secure location. Appropriate user rights are designated for each of your employees so they can access the appropriate network resources (i.e. drives, printers, etc.).
- **Cost effective solution**
For departments that need on-site personalized desktop support and secure file storage, WNC provides an economical solution. WNC will be happy to consult with you regarding your department's specific requirements.
- **Coordination of support**
WNC provides a single point of contact for computer assistance, working closely with other UIITS departments and outside vendors to resolve technical problems.
- **Consulting services**
We research future IT trends in order to stay current with technology so we can help departments make informed decisions. Working closely with representatives from your department, we provide recommendations for hardware and software purchases.
- **Asset Management**
Using asset management software, we provide up-to-date equipment inventory and warranty tracking to our customers.

See also: [Desktop file backup when files located on server operated by UIITS.](#)

How to Access or Request

For more information about our services, contact Workgroup & Network Consulting at wnc@list.arizona.edu.

For Support and Assistance

[24/7 Support Center](#)

Hours of Availability

Monday through Friday, 8:00 a.m. to 5:00 p.m.

Service Location

At the customer desk

Workgroup and Network Consulting - Computer Center Room 112

Cost of Service

Full service - Approximately \$800 annually per workstation

Terms and Conditions

Customer must be affiliated with the University of Arizona.

Escalation Contact

Patti Fastje

UITS - COMMUNICATION USER FTE NETWORK FUNDING MODEL

FY 2016 - 2017

FTE Overview and Procedure for Account Number Assignment

Communication User FTE Network Funding Model Overview

- The Communication User FTE Network Funding Model is the mechanism by which University Information Technology Services (UITS) recovers a portion of the costs of providing data and voice connectivity to University of Arizona campus customers.
- This model is based on Full Time Equivalent (FTE), as reported in UA Fact Book census counts.
- In the first year, FY 2008-2009, the Model was “Budget Neutral”, in that UITS collected the same number of dollars on an FTE basis as it collected in the baseline year on a per service basis. There was a one-time permanent budget transfer in the first year of implementation to assure that each college/division had sufficient budget for its FTE Charge in the first year.
- **For FY 2016-2017, the FTE Rate will continue at \$776 per FTE**, the same rate it has been since FY 2008-2009.

UAccess Analytics FTE Data

- The FTE Count and FTE Charge are provided in UAccess Analytics. That information is located on the Financial, General – IT Services Dashboard, on the Communication User FTE FY16-17 tab.
 - **Financial → General - IT Services → Communication User FTE FY16-17**
- The prompts allow query of FTE Count and FTE Charge by name at various levels of granularity. The data can be queried at the employee, account, department, college, super college, and VP levels.

Action Required of Colleges/Divisions

- **Provide KFS account number(s).** UITS asks Colleges/Divisions to provide the KFS account number(s) for the Communications User FTE Network Funding Model Charge. The Excel template (FTE Submittal Template FY16-17) is to be used to submit this information to UITS.
- **To aid in reconciliation:** UITS requests that one FTE Submittal Template be completed per Department if at all possible. If multiple departments are combined on one template, *please be sure to indicate which amounts and accounts are in payment towards which department* using the “YOUR Dept Number” column in the payment section of the submittal template.
- **Submittal Template format:** *please do not submit the template in PDF format or change the existing formatting in any way.* The Excel format provided allows for direct upload into the UITS billing system, which eliminates the possibility of keystroke errors that may arise from hand-keying your department information into the system.
- **KFS account information is due Friday, December 2nd, 2016.** Please email the completed Excel template to Gabriel Lopez, Director, and Meryn Finity, FTE Project Lead, UITS Business Services and Finance, at the following address:

UITS-FTEcharge@email.arizona.edu

Supporting Details

- The FTE Charge is the product of the \$776 FTE Rate and the FTE Count.
- In determining the FTE Count, UITS starts with institutionally reported FTE, as reported in the UA Fact Book. The previously established exceptions for employees not considered Communication Users will continue. These exceptions are largely for job titles such as Animal Caretakers, Custodians, and Groundskeepers.
- The FTE Count is based on a single data point, the UA Fact Book census date of October 1, 2016.
- The FTE Charge is based upon employee funding allocation as of the UA Fact Book census date of October 1, 2016. For example: For an employee paid .50 FTE by Department A and .50 FTE by Department B, each of those departments will see .50 of the full FTE charge for that employee on the Analytics report, and is responsible for payment of their share of the charge.
- The FTE Count may be validated by department, by account, and by name using the UAccess Analytics query, as described above. Multiple accounts may be used for the FTE Charge. The critical aspect of assigning dollars to accounts is to assure the totals agree with the FTE Charge total at the college/division level.
- The FTE Charge may be assigned to an account which did not exist at the time of the FTE Count.
- Federal grants and contracts (generally, account range 3000000 to 4199999) may not be used.
- At this time, our billing system cannot accept KFS sub-account, sub-object codes, or project codes.
- The account information will be used by UITS to bill the Communication User FTE Charge expenditure. For FY 2016-2017, the charge will post in November or December 2016, depending on the payment information submission date. The charge will be a one-time annual amount. However, if there is an account type that cannot be billed annually, it may be billed on a quarterly basis, by designating this on the submittal template. For those accounts that will be billed quarterly the December billing will be for two quarters.

Resources for Assistance

- UITS Support:

UITS-FTEcharge@email.arizona.edu

All inquiries to the above email address will be received by:

Meryn Finity
FTE Project Lead
Business Services & Finance
626-1043

and

Gabriel Lopez
Director, Business Services & Finance
626-5238

- uits.arizona.edu/fte

UNIVERSITY OF ARIZONA
FACILITIES AND ADMINISTRATIVE COST RATES

EXHIBIT A

	ORGANIZED RESEARCH		INSTRUCTION		OTHER SPONSORED ACTIVITIES	
	JULY 1, 2016 THROUGH JUNE 30, 2020		JULY 1, 2016 THROUGH JUNE 30, 2020		JULY 1, 2016 THROUGH JUNE 30, 2020	
	ON-CAMPUS	OFF-CAMPUS	ON-CAMPUS	OFF-CAMPUS	ON-CAMPUS	OFF-CAMPUS
BUILDING	4.6%		3.4%		3.1%	
EQUIPMENT	3.0%		1.0%		1.5%	
INTEREST	3.5%		2.1%		0.9%	
OPERATIONS & MAINTENANCE	14.3%		10.0%		11.5%	
LIBRARY	2.1%		7.5%		4.0%	
GENERAL ADMINISTRATION	5.8%		3.7%		4.7%	
DEPARTMENT ADMINISTRATION	17.4%		10.7%		19.0%	
SPONSORED PROJECTS ADMINISTRATION	2.8%		1.8%		2.3%	
STUDENT SERVICES	0.0%		9.8%		0.0%	
ADMINISTRATION COMPONENTS	26.0%	26.0%	26.0%	26.0%	26.0%	26.0%
TOTAL	53.5%	26.0%	50.0%	26.0%	47.0%	26.0%

ADMINISTRATIVE COMPONENTS ARE CAPPED AT 26.0% IN ACCORDANCE WITH OMB A-21, DATED JULY 26, 1993.
CONCUR:

(SIGNATURE)

Senior Vice President for Business Affairs and Chief Financial Officer

TITLE

9/9/16

DATE

**Financial Services Office - Office of Investments
Arizona State Museum Investment Sample Report
January 11th, 2017**

December 31st, 2016 - Earnings Summary

Average Monthly Balance	\$ 1,000,000
Monthly Rate*	0.121%
Monthly Return	\$ 1,213
Ending Balance	\$ 1,001,213

Operating Fund - Return Summary:
Fiscal Year 2017 - End of December 31, 2016

Average Monthly Rate	Average Monthly Rate (Annualized)
0.145%	1.725%

Date	Monthly Rate	Monthly Rate (Annualized)
Jul-16	0.143%	1.69%
Aug-16	0.137%	1.61%
Sep-16	0.169%	2.06%
Oct-16	0.139%	1.63%
Nov-16	0.159%	1.93%
Dec-16	0.121%	1.43%

Asset Type Allocation

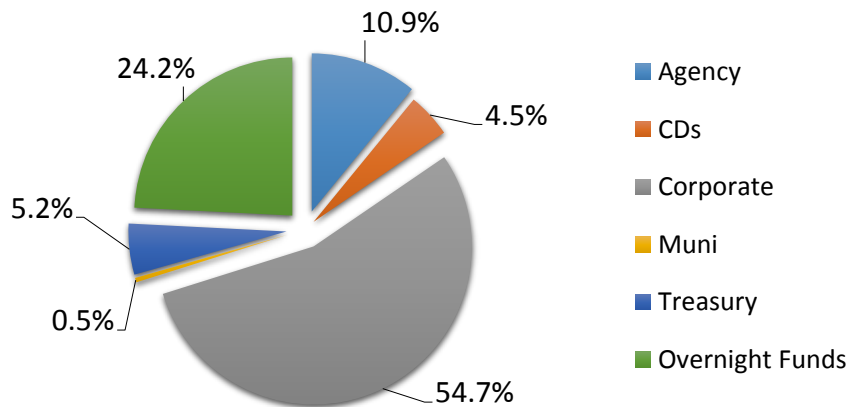

*Blended rate based on University's operating fund portfolio's monthly earnings